

CAUTION

R. Litz and Sons

Safe Work Practices

Safe Work Practice

Table of Contents

*Sign & fax the Safe Work Practice Sign Off Sheet, at the end of this document, once you have read and understood Sections 1-53. Click the links below for rapid access to each section.

1. 5 Point Harness Inspection
2. Aerial Buckets
3. Aerial Devices
4. Asbestos
5. Cable Clips and Clamping Wire Rope
6. Chain Saw – Basic Operation
7. Chain Saw – General Safety
8. Chain Saw – PPE
9. Chain Saw – Safe Use Of
10. Chemical Hazard Recognition
11. Chop Saw
12. Clothing in the Electrical Industry
13. Compressed Air – Use
14. Compressed Gas – Cylinder Storage
15. Compressed Gas – Regulator Use
16. Confined Space
17. Construction Labourers
18. Directional Drilling
19. Electrical – Live Apparatus
20. Electrical Safety
21. Electrical Shock Protection
22. Explosive Actuated Fastening Tool
23. Extension Cords
24. Extension Ladder
25. Extreme Temperature Work
26. Fire Precautions
27. First Aid for Chemical Exposure
28. First Aid
29. Flammable Liquids
30. Grinders – Portable
31. Grinding
32. Guardrails
33. Hack Saw
34. Hand Saw Safety
35. Hazardous Material Precautions
36. High Voltage Lines
37. Hoisting Personnel
38. Hot Work

39. Hypothermia
40. Illumination & Fixed Temporary Lighting
41. Labelling Containers
42. Ladders – Extension Safety
43. Ladders – Extension Set Up
44. Ladders – Portable Safety
45. Lock Out – Tag Out – Do's and Don'ts
46. Lock Out – Tag Out
47. Mobile Equipment
48. Particulates and the Respiratory System
49. Pipe Bending
50. Propane Heaters
51. Small Tools
52. Welding
53. Winter Driving
54. Employee Safe Work Practices Sign Off Sheet

LITZ
CRANE & RIGGING

R. LITZ & SONS Co. Ltd. www.litzcranes.com
277 McPhillips St.
Winnipeg, Mb. R3E 2K7
Ph: (204) 783-7979
Fax: (204) 775-3250
Toll free: 1-888-CRANE03

MEMBER
SC&RA
info@litzcranes.com

'SERVING INDUSTRY SINCE 1903'



SWP – 5 Point Harness Inspection

Do's

- Lanyards must have locking snap hooks or carabineers that are auto-locking
- Visually inspect all snap hooks and carabineers and be sure that they freely engage and that the keeper is fully closed and locked
- Do check all webbing frayed edges, broken fibres, pulled stitches cuts burns and chemical damage
- Do check rings for any broken, corroded, distorted, rough or sharp edges or fatigued metal
- Inspect all buckles ensure that there is no unusual wear damage or distortion, that all parts move freely,
- Check stitching for pulled or ripped stitches make sure webbing is not loose at the joints
- Do check pads on harness for damage, cracks or excessive wear
- Check for any missing pieces, latches, buckles or parts

Don'ts

- Never use a malfunctioning harness
- Don't disable or restrict a locking keeper or alter any connecting device
- Allow webbing of harness or metal to be subject to high temperature surfaces or direct flame
- Subject harness to chemicals
- Tie knots in harness in order to take up slack or because there is a malfunction in the harness
- Forget to check your lanyard as well

Tips

1. Check harness daily before use
2. Check connecting linkage and straps
3. Check snap hook on the line; it must be locking
4. Put on harness
5. Adjust straps so the harness is properly fitted to the worker
6. Snap hook is to be fastened to a lifeline or a secure anchor point

LITZ

CRANE & RIGGING

R. LITZ & SONS Co. Ltd. www.litzcranes.com

277 McPhillips St.
Winnipeg, Mb. R3E 2K7
Ph: (204) 783-7979
Fax: (204) 775-3250

Toll free: 1-888-CRANE03



info@litzcranes.com

'SERVING INDUSTRY SINCE 1903'

SWP – Aerial Buckets

1. Before raising the bucket the out riggers shall be lowered into position in solid footing to level and stabilize machine
2. The vehicle shall not be moved while the aerial bucket is in an elevated position or occupied
3. Aerial Buckets shall not be considered as insulated platforms other than units certified for bare hand live-line maintenance
4. All fall arrest protection required shall be worn at all times
5. Safety straps shall be properly installed and worn by Employees while working aloft in buckets
6. When traveling with a bucket truck the boom shall be clamped down
7. If covers are supplied for buckets they must be installed to protect the bucket when it is not actually in use



CRANE & RIGGING

R. LITZ & SONS Co. Ltd. www.litzcranes.com

277 McPhillips St.
Winnipeg, Mb. R3E 2K7
Ph: (204) 783-7979
Fax: (204) 775-3250

Toll free: 1-888-CRANE03



info@litzcranes.com

'SERVING INDUSTRY SINCE 1903'

SWP – Aerial Devices

1. Only employees who are properly trained and qualified shall use or operate this type of equipment. An employee who is trained and qualified to operate the lower controls shall be present while any employee is aloft.
2. The Operating and maintenance instruction manuals issued by the manufacturer shall be followed
3. Where aerial devices are equipped with outriggers the outriggers shall always be lowered and set before the boom is raised from the travel position
4. When outriggers are used they shall be set on pads or a solid surface
5. Manufacturers load limits of the boom and bucket shall not be exceeded. Shock loading (sudden stops or starts) of the equipment shall be avoided.
6. Aerial devices shall not be “field modified” unless such modifications are certified by the manufacturers. The insulated portion shall not be altered in any manner that might reduce its insulating value.
7. Prior to use the equipment shall be given a warm-up period. The hydraulic system and the lift controls shall be checked and tested daily before use to determine that such features are in a safe working condition. Malfunction or unsafe operational condition shall be corrected immediately or reported. Equipment which is not in proper operation condition shall not be used.
8. Lower level controls shall not be operated unless permission has been obtained from the employee in the bucket, except in case of emergency employees shall be taught and shall practice emergency lowering procedures.
9. Only one employee shall be allowed to work from a bucket rated for a single man
10. When two employees are working from a bucket, one of them shall be designated to operate the controls and shall give all signals

****For further information, see the appropriate current Occupation Health and Safety Regulations****

LITZ
CRANE & RIGGING

R. LITZ & SONS Co. Ltd. www.litzcranes.com
277 McPhillips St.
Winnipeg, Mb. R3E 2K7
Ph: (204) 783-7979
Fax: (204) 775-3250
Toll free: 1-888-CRANE03

MEMBER
SC&RA
info@litzcranes.com

'SERVING INDUSTRY SINCE 1903'



SWP – Asbestos: Testing and Removal

Asbestos is often off-white; less-common types are blue or brown. Its appearance generally depends upon the material it was mixed with to make it workable like cement, polymers, starch, asphalt, or other binders. Here's where to look for asbestos and what to do if you find it:

Heating ductwork Some ducts, particularly in Southern California, are made largely of asbestos; other metal ducts are wrapped with cellulose-asbestos air-cell insulation. Both look a bit like off-white corrugated cardboard; asbestos sheeting insulation has a similar appearance but not the corrugations. In addition, registers may have asbestos taping inside.

Ductwork made of asbestos is a major concern because when it begins to deteriorate, fibers are blown into the house. Talk with an asbestos abatement contractor about removal. Removing ductwork costs from \$12 to \$25 per linear foot, from \$1000 to \$2000 in a standard basement. Replacement is additional. Wrapped ducts should be removed if wrapping is friable. A stop-gap measure for duct wrapping that is sound have it encapsulated.

The furnace may have an asbestos lining at the base or sit on an asbestos pad. A special asbestos cloth may join furnace or boiler to ductwork. If any of these are exposed to damage, they should be encapsulated or removed.

Plumbing Some pipes particularly those connected to radiators or steam heat are jacketed with asbestos. Asbestos pipe wrap, often covered with canvas, has a crumbly white surface. If pipe wrap has small holes, it's generally better to repair it than remove it. You can caulk holes then wrap with re-wettable class cloth. Don't use duct tape – it will fall off with time.

Wiring Be wary of old know-and-tube wires that have a white coating covered with black fabric. If you're remodelling, avoid pulling out these old wires; bypass with new wiring.

Fireplace Artificial logs are ashes manufactured prior to 1978 probably contain flaking asbestos. The ashes are a serious concern; the ashes are a serious concern; remove them immediately. The logs don't release fibres unless friable.

Wood-stove gaskets and protective panels for wood stoves or ovens may look like greyish-white stone. If exposed to damage, remove and replace with acceptable material.

Crawl space or basement floor. Remember that fibres may have collected on the ground or floor beneath ductwork or piping. Have this area cleaned by a trained asbestos abatement professional or if you must – wet mop to clean up. Never sweep or vacuum asbestos fibres – are about one-thousandth the thickness of a human hair and will go right through a household vacuum and into the air.

Walls and ceilings. Sprayed acoustical “cottage cheese” ceilings apparently have a very low percentage of asbestos, though some may contain as much as 40 percent. Avoid doing anything that will loosen the material (for example, don’t sweep the ceiling). Removal can be quite expensive (from \$5 to \$30 per square foot).

Most patching plaster and drywall joint compounds – until 1979 – contained a small amount of asbestos. Avoid scraping and sanding them.

Some plaster walls in older homes contain blown-in insulation that includes asbestos; it looks like hard cotton. Only have this removed if you’re remodelling.

Flooring Even recently-manufactured vinyl floor tiles contain a modest amount of asbestos. Because it is ingrained in the material, it doesn’t pose a threat. The tile and its felt backing only become a problem when you’re renovating. Don’t sand or scrape these materials. Rather than remove old vinyl flooring, the best recommendation is to cover it with underlayment, then add your new floor. Roofing and siding. Some older shingles are made from asbestos mixed with cement or asphalt-asbestos shingles don’t release fibres easily; asbestos-roofing tars and felts also contain asbestos but, again are unlikely to release fibres unless heavily damaged.

Resources:

Consumer product safety commission 1-200-638-2772

Environmental protection agency 1-202-554-1404



CRANE & RIGGING

R. LITZ & SONS Co. Ltd. www.litzcranes.com

277 McPhillips St.
Winnipeg, Mb. R3E 2K7
Ph: (204) 783-7979
Fax: (204) 775-3250

Toll free: 1-888-CRANE03



info@litzcranes.com

'SERVING INDUSTRY SINCE 1903"

SWP – Attaching Cable Clips and Clamping Wire Rope

General:

1. Wire the thimble to the rope at the desired point, then bend the rope around the thimble and secure temporarily by wiring the rope members together.
2. First attach the clip farthest from the thimble and tighten (be sure the base of the saddle rests upon the live end of the rope and the “U” bolts on the short end). All clips must be attached in this manner.
3. The clip nearest the thimble goes on next. Do not tighten yet. If one or more additional clips are to be attached, place them at an equal distance apart between the clips already attached.
4. Before tightening, place some stress on the rope to take up the slack and equalize the tension on both sides of the clip. (Do not apply too much stress or the clip attached in step 1 will not hold.) Tighten all clips.

Diameter of Rope (mm)	Number of Clips	Spacing Between Clips Center to Center(mm)	Torque (Newton-metres)
6	2	38	20
8	2	51	40
10	2	57	65
11	2	64	90
12	3	76	90
16	3	102	135
19	4	114	176
22	4	133	305
25	4	152	305

29	5	178	305
32	5	203	488
38	6	229	488
44	7	267	628
50	8	305	881

Incorrect U-bolt of all clips on live end of rope	Incorrect Do not stagger clips
Correct U-Bolt of all clips on live end of rope	Attachment methods

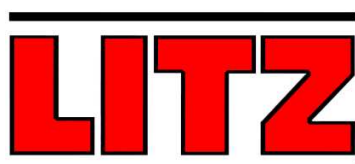

CRANE & RIGGING

R. LITZ & SONS Co. Ltd. www.litzcranes.com

277 McPhillips St.
Winnipeg, Mb. R3E 2K7
Ph: (204) 783-7979
Fax: (204) 775-3250

Toll free: 1-888-CRANE03



info@litzcranes.com

'SERVING INDUSTRY SINCE 1903'

SWP – Chain Saw – Basic Saw Operation

1. Felling – Cutting Down a Tree

- Notify the proper authorities before felling near buildings, power lines or roads
- Size up tree for diameter and direction of lean before cutting
- Choose direction of fall according to wind direction, lean and shape of tree make sure tree has a clear area to fall into
- Clear work are of brush and debris before cutting down the tree
- Clear escape path to rear at 45° angle from direction of fall
- Warn persons in area that a tree is falling. Direct them to stand at least 2 tree lengths away
- Move at least 7.5m (25 feet) away, when tree starts to fall, turn saw off, and lay it behind trunk base

2. Controlling Direction of Fall

- Make the undercut facing the direction of fall. Undercut 1/3 tree's diameter
- Make the back-cut stop just short of undercut leaving 2.5cm (1 inch) wedge of wood to help control direction of fall. Back-cut 5 cm (2 inches) above undercut
- Use ropes or wedges to guide fall in direction other than natural lean

3. Limbing – Removing branches from felled trees

- Stand firmly on ground. Cut limbs on far side first, then near side. If ground slopes, stand on uphill side. Do not cut limbs that are supporting the log – roll log first.

4. Bucking – Cutting a log into shorter lengths

- Clear the work area. Plan the cut. A vertical cut avoids binding. If possible, prop up the end to be cut off using another log.
- Cut compression side first, tension side last
- Keep feet away from trunk while bucking

5. Pruning – Cutting limbs from a standing tree

- Keep both hands on the saw, both feet on the ground and maintain balance at all times. Work at shoulder height or below. Undercut limb first then cut from top



CRANE & RIGGING

R. LITZ & SONS Co. Ltd. www.litzcranes.com

277 McPhillips St.
Winnipeg, Mb. R3E 2K7
Ph: (204) 783-7979
Fax: (204) 775-3250

Toll free: 1-888-CRANE03

MEMBER

SC&RA



info@litzcranes.com

'SERVING INDUSTRY SINCE 1903'

SWP – Chain Saws – General Safety

1. Ensure all workers are properly trained on the safe use and handling of chain saws
2. All persons must wear the appropriate Personal Protection Equipment
3. All gas chain saws must be used in properly ventilated areas.
4. Saw must be off and cool to refuel
5. Ensure chain is sharp and free of defects
6. Ensure proper chain tension is maintained
7. Ensure proper chain lubrication is maintained during cutting
8. Carry fuel in an approved container only
9. Ensure manufacturer's instructions are followed for proper use and handling
10. Do not cut above shoulder height

LITZ
CRANE & RIGGING

R. LITZ & SONS Co. Ltd. www.litzcranes.com
277 McPhillips St.
Winnipeg, Mb. R3E 2K7
Ph: (204) 783-7979
Fax: (204) 775-3250
Toll free: 1-888-CRANE03

MEMBER
SC&RA
info@litzcranes.com

'SERVING INDUSTRY SINCE 1903'



SWP – Chain Saw – Personal Protective Equipment

Use proper safety clothing to reduce the risk of injury. The following personal protective equipment (PPE) is recommended when operating a chain saw.

Eye Protection

CSA – approved safety glasses and face-shield. A face-shield attached to the hard hat without safety glasses does not provide the adequate eye protection

Head Protection

CSA – Approved hard hat, highly visible in colour

Hearing Protection

CSA – approved hearing protection. (Chain saws create high noise levels 95dBA – 115 dBA)

Gloves and Mitts

Leather gloves with ballistic nylon reinforcement on the back. They offer a good grip on the saw, protect the hands and absorb some vibration.

Leg Protection

Trousers or chaps with sewn-in ballistic nylon pads. Close fitting clothing without cuffs, made of close-woven fabrics.

Foot Protection

Heavy, well-fitted, CSA – approved safety work boots. Boots made of ballistic nylon offer the best cut protection. Rubber shoes for wet weather and snow and hobnail boots, grip soles or cork soles for rough terrain.



CRANE & RIGGING

R. LITZ & SONS Co. Ltd. www.litzcranes.com

277 McPhillips St.
Winnipeg, Mb. R3E 2K7
Ph: (204) 783-7979
Fax: (204) 775-3250

Toll free: 1-888-CRANE03



info@litzcranes.com

'SERVING INDUSTRY SINCE 1903'

SWP – Chain Saws – Safe Use of Chain Saws

- Wear personal protective equipment.
- Operate, adjust and maintain saws in accordance with CSA Standard Z62.1-M-77 “Chain Saws” and manufacturers’ directions
- Review pertinent Health and Safety Legislation before operating a chain saw. Operate the chain saw in well –ventilated areas only

1. Fuelling

- Follow manufacturer’s directions for oil/gas mixture
- Mix Fuel in a well- ventilated area. Keep a fire extinguisher nearby. Do not smoke or allow any ignition sources while refuelling
- Do not refuel a running or hot saw
- Store fuel in an approved safety container. Use funnel or spout for pouring, wipe of any spills

2. Starting the Saw

Do’s

- Inspect the saw before starting. Do not use a saw with damaged, loose or missing parts
- Ensure that the guide bar is tight and chain fits snugly without binding
- Know how to use the controls before starting a chain saw
- Ensure that chain is clear of obstructions before starting chain saw
- Hold the saw firmly on the ground. Point the chain away from your body and nearby obstructions. Use a quick sharp motion on the starter cord.

- Warm up the saw prior to cutting. The saw should idle without the chain turning, if the chain continues to turn after the throttle switch is released, stop the saw. Then adjust the idle as shown in the owner's manual.

Do Not's

- Do not "Drop Start" (starting saw in hands). This leaves only one hand to control a running saw and has resulted in leg cuts
- Do not start saw unless it is at least 3 meters or 10 feet from approved fuel safety container
- Do not make adjustments to chain or guide bar when motor is running

3. Cutting

Do's

- Plan each job before you start. Arrange to have help if you need it
- Know the location of the persons working with you at all times
- Use the correct saw. The weight, power and bar length should all be suitable for the job
- Operate chain saw in a firm two-handed grip with fingers and thumb surrounding the handles. Keep both feet firmly positioned when operating a chain saw
- Maintain full power throughout each cut
- Keep your saw clean – free of sawdust, dirt and oil

Do Not's

- Do not stand directly behind the saw
- Do not leave a saw running unattended
- Do not carry chain saw with saw running
- Do not cut alone

LITZ
CRANE & RIGGING

R. LITZ & SONS Co. Ltd. www.litzcranes.com
277 McPhillips St.
Winnipeg, Mb. R3E 2K7
Ph: (204) 783-7979
Fax: (204) 775-3250
Toll free: 1-888-CRANE03

MEMBER
SC&RA
info@litzcranes.com

'SERVING INDUSTRY SINCE 1903'



SWP – Chemical Hazard Recognition

Types of Chemical Hazards

- Flammable Liquids or Solids
- Combustibles
- Explosives
- Organic Peroxides
- Oxidizers
- Unstable Materials

Health Hazards can either be:

- Acute – Short term symptoms/begins right away
- Chronic – Long-term affects/Not noticed for a period of time

Chemicals can enter the body through either:

- Absorption
- Inhalation
- Injection
- Ingestion

The use of all required PPE and routine hand washing can prevent chemical exposure.

Methods that personnel can protect themselves from hazardous chemicals and situations are:

- Eliminate sources of flame or ignition
- No smoking in flammable materials area
- Good ventilation is important in preventing toxic or dangerous gas build up
- Specially designed containers for flammable liquids should be used
- Limit the number of flammable materials

- Clean spills promptly
- No open containers when chemicals are not in use
- Rags that contain a flammable substance should be placed in self-closing metal containers
- Appropriate Personal Protective Equipment Should be worn

LITZ

CRANE & RIGGING

R. LITZ & SONS Co. Ltd. www.litzcranes.com277 McPhillips St.
Winnipeg, Mb. R3E 2K7
Ph: (204) 783-7979
Fax: (204) 775-3250

Toll free: 1-888-CRANE03

info@litzcranes.com

'SERVING INDUSTRY SINCE 1903"

SWP – Chop Saw

General:

The “chop saw” or power mitre box is a commonly used tool in our industry. Lack of respect for any saw can cost you dearly. Not just lost time and pay but lost eyes and fingers as well

- Always wear approved safety equipment, such as safety glasses, face-shield and ear protection
- Select the proper blade for the material you are cutting
- When possible, clamp the material you are cutting, especially compound mitre saws.
- Never “feed” material into the blade of a chop saw
- Never apply lubricant, waxes etc. directly to a moving blade
- Power supply must be disconnected prior to changing the blade
- Maintain equipment (cracked cords, etc)

LITZ
CRANE & RIGGING

R. LITZ & SONS Co. Ltd. www.litzcranes.com
277 McPhillips St.
Winnipeg, Mb. R3E 2K7
Ph: (204) 783-7979
Fax: (204) 775-3250
Toll free: 1-888-CRANE03

MEMBER
SC&RA
info@litzcranes.com

'SERVING INDUSTRY SINCE 1903'



SWP – Clothing in the Electrical Industry

Synthetic Clothing: A Deadly Hazard in the Electrical Environment

Tests indicate when electrical arcs occur, the wearing of spandex, polyester, nylon and most blends of these products drastically increase the odds that you will receive burns to 100% of your body covered by these materials. In addition, their presence may also inhibit the treatment/recovery process.

Electric arcs can generate such intense heat that in less than one half second they can melt tools and ignite everyday clothing such as polyester and nylon. Once this clothing ignites, it continues to burn and increase injury to the wearer.

Protect Yourself!!

Wear clothing made of natural fibres like 100% cotton or 100% wool treated with a flame retardant chemical to provide protective qualities. These products may burn but they don't melt or continue to burn once the ignition source is removed. You may still receive a burn but it will not be compounded by the instant ignition and melting of your clothes.

From various tests conducted, another type of protective apparel known as Nomex IIIA resists the intense heat and flame hazards associated with exposure to electric arcs. This type of protective clothing will provide an extra measure of safety in the event of an inadvertent arcing taking place.

No matter what type of outer garment worn, electric arcs can generate such extreme heat that they can melt, undergarments made from synthetic materials such as polyester and nylon. To reduce this hazards, wear 100% cotton t-shirts and underwear under your outer garments to provide protection to the vital areas of your body.

What you wear can make a difference!

Don't become a statistic!

LITZ
CRANE & RIGGING

R. LITZ & SONS Co. Ltd. www.litzcranes.com
277 McPhillips St.
Winnipeg, Mb. R3E 2K7
Ph: (204) 783-7979
Fax: (204) 775-3250
Toll free: 1-888-CRANE03

MEMBER
SC&RA
info@litzcranes.com

'SERVING INDUSTRY SINCE 1903'

SWP – Use of Compressed Air

Air Powered Tools in construction range from stapling guns to jack hammers. If not treated with respect, these tools can become a powerful enemy rather than a servant.

- Compressed air must not be used to blow debris or to clear dirt from any workers clothes
- Ensure that the air pressure has been turned off and the line pressure relieved before disconnecting the hose or changing tools
- All hose connectors must be of quick disconnect pressure release type with a “safety chain/cable.”
- Wear personal protective equipment such as eye protection and face shields and ensure other workers in the area are made aware of or have restricted access to the hazard area
- Hoses must be checked on a regular basis for cuts, bulges, or other damage. Ensure defective hoses are repaired or replaced
- A proper pressure regulator and relief device must be in the system to ensure that correct desired pressure are maintained
- The correct air supply hoses must be used for the tool/equipment being used
- The equipment must be properly maintained according to the manufacturers specifications
- Follow manufacturers general instructions and comply with legislated safety requirements



CRANE & RIGGING

R. LITZ & SONS Co. Ltd. www.litzcranes.com

277 McPhillips St.
Winnipeg, Mb. R3E 2K7
Ph: (204) 783-7979
Fax: (204) 775-3250

Toll free: 1-888-CRANE03



info@litzcranes.com

'SERVING INDUSTRY SINCE 1903'

SWP – Compressed Gas Cylinder Storage

- Store cylinders in a dry, well-ventilated area, away from heat or ignition sources. Cylinders are not designated for temperatures above 54° Celsius (130° Fahrenheit) Make sure valve protection caps are in place.
- Store oxidizing gas and flammable cylinders at least 6 meters (20 ft) apart or separate by 1.5 meters (5 ft) high wall with a half-hour fire resistance rating
- Keep cylinders at least 6 meters (20 ft) from flammable materials such as paint oil or solvents.
- Log each cylinder in and out, recording the serial number stamped on the cylinder and the contents. If the cylinder contents are unknown, clearly label “contents unknown” and notify the supplier for disposal. Colour codes are not reliable indicators of cylinder contents

Checklist

- Define storage areas according to cylinder content: flammable, oxidizing/inert.
- Use cylinders in rotation as received from the supplier
- Plan storage layout so that old stock can be removed first with little handling or other cylinders
- Limit laboratory storage to only those cylinders in use
- Identify storage areas post “No Smoking” signs and enforce rule
- Keep all cylinders and fittings where they cannot be contaminated by oil or grease
- Secure cylinders whether full or empty, upright by straps, chains or a stand to prevent them from falling
- Ensure that all cylinders are marked clearly, if not refuse delivery
- Keep full and empty cylinders apart to prevent accidental part-filling or an empty cylinder by back-feeding
- Close valves of empty cylinders. Fit protection caps. Mark empty cylinders “MT” Return cylinders promptly to the supplier
- Protect cylinders from extremes of weather, such as ice, snow and direct sunlight.
- Store cylinders away from elevators, stairs, doorways and aisles

LITZ R. LITZ & SONS Co. Ltd. www.litzcranes.com
277 McPhillips St.
Winnipeg, Mb. R3E 2K7
Ph: (204) 783-7979
Fax: (204) 775-3250
Toll free: 1-888-CRANE03
MEMBER
SC&RA
info@litzcranes.com
CRANE & RIGGING 'SERVING INDUSTRY SINCE 1903'

SWP – Compressed Gas Regulator Use

On

- Check that flow control valve is closed
- Turn the pressure adjusting screw counter clockwise until it turns freely
- Slowly open the cylinder valve fully
- Check the cylinder pressure gauge for expected value. A difference indicates that valve, safety device or plugs are leaking
- Turn the pressure adjusting screw clockwise until the required pressure is reached
- Control the gas flow by the flow control valve

Off

- Shut cylinder valve first
- Allow residual gases in valves to drain
- Shut pressure adjusting screw when gauges fall to zero
- Close the flow control valve

DO NOT ADJUST pressure by using the regulator to control low rates. This defeats the purpose of the pressure regulator. When higher flows are obtained by this way, the pressure may be above the design of the system.

Maintenance Check

- Check non-corrosive gas regulators (nitrogen and helium) monthly
- Check corrosive gas regulator (chlorine and hydrogen sulphide) monthly

The procedure for checking regulators is as follows:

- Drain all pressure from the system. Gauges should read zero
- Open cylinder valve and turn pressure adjusting screw counter clockwise until it turns freely. The high pressure gauge should register the cylinder pressure. The delivery outlet pressure gauge should not indicate any pressure
- Check the delivery pressure gauge to ensure it does not indicate a pressure increase after waiting ten minutes with the regulator outlet valve closed
- Turn the pressure adjusting screw clockwise until delivery pressure is indicated. Failure to attain a proper delivery pressure setting or abnormal adjustments of the screw indicates improper operation
- Close the cylinder valve and observe the pressure on both cylinder contents and delivery sides of the regulator. A drop in pressure reading after 10 minutes indicates a leak in the system
- Ensure that only the supplier makes the repairs

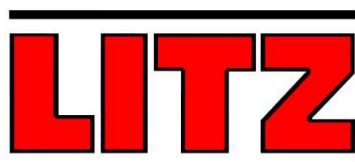

CRANE & RIGGING

R. LITZ & SONS Co. Ltd. www.litzcranes.com

277 McPhillips St.
Winnipeg, Mb. R3E 2K7
Ph: (204) 783-7979
Fax: (204) 775-3250

Toll free: 1-888-CRANE03



info@litzcranes.com

'SERVING INDUSTRY SINCE 1903'

SWP – Confined Space

A confined work area is one in which access or egress is restricted and dangerous air contamination is a potential threat. The hazards of a confined work area entry, is that hazards are not always seen, smelled or heard. What may appear to be a harmless situation may actually be a deadly situation.

Do's

- Be trained and competent in confined space entry prior to performing work
- Must have received H2S alive or equivalent training
- Wear all appropriate PPE
- Always have venting for the confined space
- Perform air monitoring prior to entry and ensure that it is safe to do so
- Continuously monitor the air for any changes while work is being performed
- Have an established method of communication from the workers performing the work and the rescue personnel and a confirmed alarm system
- Do not enter without rescue personnel present
- Ensure that there is a reasonable means of exit from the confined space
- Must have received H2S alive or equivalent training
- Use proper respiratory protection

Don'ts

- Perform work that you have not been trained to do
- Enter spaces that have not been blanked out or locked out
- Enter any space that has not been air tested
- Be unaware of the proper emergency procedure
- Don't enter a confined space without a permit
- Enter a confined space without being aware of the hazards that are present

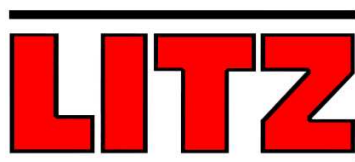

CRANE & RIGGING

R. LITZ & SONS Co. Ltd. www.litzcranes.com

277 McPhillips St.
Winnipeg, Mb. R3E 2K7
Ph: (204) 783-7979
Fax: (204) 775-3250

Toll free: 1-888-CRANE03



info@litzcranes.com

'SERVING INDUSTRY SINCE 1903'

SWP – Construction Labourers

Do's

- Wear all appropriate PPE
- Inspect work area before starting any task
- Make eye contact with equipment operators to ensure they see you
- Stay alert and periodically look at surroundings to ensure safety
- Request assistance to move all heavy or awkward objects
- Practice good house keeping
- Keep tools and equipment in good working order

Don'ts

- Engage in horseplay
- Not report any hazards to your supervisor
- Use machinery for which you are not trained
- Use awkward body positions and take infrequent breaks

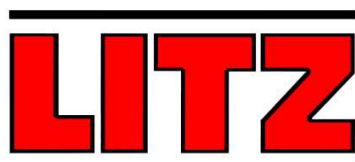

CRANE & RIGGING

R. LITZ & SONS Co. Ltd. www.litzcranes.com

277 McPhillips St.
Winnipeg, Mb. R3E 2K7
Ph: (204) 783-7979
Fax: (204) 775-3250

Toll free: 1-888-CRANE03



info@litzcranes.com

'SERVING INDUSTRY SINCE 1903'

SWP – Directional Drilling

Description:

The use of drilling equipment that can travel a directed path, through the use of accurate tracking and guiding systems. It can be guided over, under and around utilities, structures, rivers and highways. A transmitter located in the bore head is tracked by a computer/receiver. The information is sent to the operator who can then direct and guide the head from the bore machine.

Do's

- Plan the bore
- Expose utilities before boring across
- Use proper placement of mats, stakes and cones
- Place grounding stakes into the ground before driving anchor stake
- Test the strike alert system before boring
- Read operating instructions and procedures
- Wear Insulated lineman's gloves and boots when assisting the operator in any capacity (i.e. greasing rods, install anchor stake, etc.

Don'ts

- Use pipe wrenches to uncouple drill rod
- Rotate the drill rod while anyone is in contact with any part of the drill string
- Modify thrusts or bore levers so they do not spring return to the off position when released
- Use drugs or alcohol
- Take unnecessary chances



R. LITZ & SONS Co. Ltd. www.litzcranes.com

277 McPhillips St.
Winnipeg, Mb. R3E 2K7
Ph: (204) 783-7979
Fax: (204) 775-3250
Toll free: 1-888-CRANE03



info@litzcranes.com

CRANE & RIGGING 'SERVING INDUSTRY SINCE 1903'

SWP – Live Electrical Apparatus

A. General

Electrical apparatus equipment and circuits shall be designed and operated in accordance with the Canadian Electrical Code

- Always know what amperage and voltage you are working on. Connecting equipment to the wrong voltage can be a hazard to equipment and personnel
- For reasons of safety, all electrical installation should be carried out by a properly trained and qualified journeyman or registered apprentices not by helpers
- Two or more journeyman must work together on any energized circuit with a potential to 480 volts or more between conductors. Implement the buddy system. This does not apply to testing or troubleshooting
- Approved eye protection, insulating gloves, mats, sleeves, and other protective equipment must be provided by the employer and used by employees as required
- Where workers are required to work on, around or dangerously live apparatus in a manhole, vault or switch-room, a suitable rescue system or lifeline of adequate length and strength must be provided at the entrance of the manhole, vault or switch-room. The rescue system or lifeline must be readily available to aid any worker “hung up” on live apparatus and to remove him from the immediate danger area.
- Metal or wire-reinforced ladders must never be used by electrical workers working on live apparatus
- Procedures must be carefully followed in reverse order when re-energizing or re-activating electrical systems
- Before working on live equipment, always locate breaker or disconnect in case of emergency
- Where work will require workers to enter utility operated substation or equipment, workers shall first obtain approval from the utility company and work under the direct supervision of the utility system

B. Electrical Panels

Remove panel covers with care. Examine for loose cover screws or panel space fillers. These can fall across the bus or splitter bars and cause a short which can blow the panel cover off and also cause a serious eye injury or burn the body. If the panel cover is too large, obtain the assistance of a capable person to help lift it off. Approved safety glasses and insulating gloves should be worn during this operation.

C. Connections

- When working on connections, shut off power if possible. If you have to work it live, take all precautions and make sure the scaffold or ladder are not grounded
- When working on high voltage, wear suitable gloves that have been tested for the voltages being worked on
- Have a properly trained and qualified electrician present with you during these operations

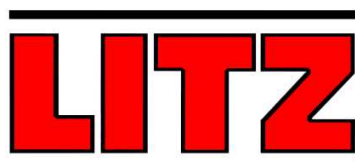

CRANE & RIGGING

R. LITZ & SONS Co. Ltd. www.litzcranes.com

277 McPhillips St.
Winnipeg, Mb. R3E 2K7
Ph: (204) 783-7979
Fax: (204) 775-3250

Toll free: 1-888-CRANE03



info@litzcranes.com

'SERVING INDUSTRY SINCE 1903"

SWP – Electrical Safety

Safety Standard Guidelines

- Any electrical work must take into account related work going on that is directly or indirectly affected by electrical power
- Employers are to ensure workers are carrying out safety related work practices and procedures and are properly trained in each job assignment
- An employee is not allowed to work in electrically hazardous area unless adequately trained to recognize and to avoid such hazards
- Fully qualified and trained workers only are to perform work on live circuits or equipment
- Exposed circuit parts that become charged are to be treated as live
- Safe work procedures must include the knowledge of specialty protective wear (where required) such as hard hats, eye protection, insulating blankets, covers, line hoses, mats and insulated gloves and sleeves
- Short cuts and poor work performance will not be tolerated
- Substandard or makeshift parts on electrical circuits or equipment cannot be used
- Classification of an area determines the hazards present and the safety aspects of the electrical circuitry and equipment to be used
- Employers are responsible for informing the worker the classification of the area his job assignment is in.
- An explosive atmosphere can be created by work procedures which require the use of chemicals, paints, solvents, etc. Therefore before energizing any circuits or equipment check for this hazard

Energized circuits and equipment

Only completely qualified and trained electricians familiar with the work assignment shall be allowed to work on live circuits or equipment and:

- Personal protection is used including insulated tools
- Are alert and not impaired by fatigue sickness or for any other reason

- Working in a well lit area that does not retard vision of any live circuits
- Are not wearing any conductive articles of clothing, jewellery such as watches, bracelets, necklaces etc.

Warnings and signs with the use of barricades can be useful in preventing or limiting access to a danger area

Electrical Safety (continued)

The following electrical safety guidelines are designed to minimize risks from hazards associated with electricity and static electricity. The guidelines shall be read in conjunction with the regulations under the Occupational Health and Safety Act or local regulatory authority which shall govern

- Work on electrical equipment and electrical power support shall only be carried out by qualified personnel
- Determine location of all underground cables before starting excavation to remove them. Shut off circuit on all high voltage cables; place tags to identify digging points; expose cables manually;
- Ensure only authorized personnel replace fuses, and;
 - Use electrically tested safety gloves
 - Stand on rubber mat
 - Shut off electric circuit

If fuses rupture periodically, repair short circuit or correct overloaded circuit.

- A heavy duty extension cord, with an isolating step-down transformer and low voltage secondary inserted in the line, shall be used with portable lighting units in damp areas;
- Follow locking and tagging procedures, before starting electrical work on electrically driven equipment

Lock-out

Only those qualified and authorized employees or contractors to AEEL may work on equipment requiring lock-out. All authorized persons must comply with this procedure when performing any maintenance or repair to any machine or equipment where contact with its moving parts could cause injury to any person.

A SITE-SPECIFIC safe work procedure shall be developed which will ensure that the equipment or machine is immobilized throughout the duration of the maintenance or repair work. After the main power supply has been turned off, an individually issued lock shall be applied to prevent the restoration of power. The person applying the first lock in a lock out procedure is responsible to immediately test to

ensure that the lock-out machinery or equipment cannot be operated. Each person must use locks assigned to him/her and labelled with his/her name or where used only occasionally, locks assigned to employee by his/her supervisor for the one operation and return lock to supervisor when job is complete.

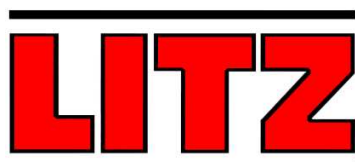

CRANE & RIGGING

R. LITZ & SONS Co. Ltd. www.litzcranes.com

277 McPhillips St.
Winnipeg, Mb. R3E 2K7
Ph: (204) 783-7979
Fax: (204) 775-3250

Toll free: 1-888-CRANE03



info@litzcranes.com

'SERVING INDUSTRY SINCE 1903'

SWP – Electrical Shock Protection

Each year statistics indicate there are electricians who are flashed and burned, service serious shocks or are otherwise injured, sometimes fatally.

- Whenever possible, avoid working on live circuits. If you must work live, INSULATE all opposite phases and grounds and ISOLATE yourself from the phase you are working on.
- Never work alone on live circuits make your partner aware of your next move, so you don't both become part of a circuit
- Until positive that the circuit is dead, assume it to be live and rated at full voltage. Don't take any ones word for it – test yourself to ensure the circuit is in face de-energized. Tag or use lock-out locks
- Where safety shoes with neoprene, crepe or rubber soles. Worn down shoes provide no insulation
- Insulating blankets should be used to cover all live components as well as grounds and enclosure metal, and protective gloves should be worn if work must be done on live bus-bars
- Test with approved test tools or equipment (a magnetic voltage tester). Don't use your fingers or lamps in series. A homemade lamp tester can be dangerous; lamps in series can explode if used on too high a voltage. Your eyes could be damaged by flying glass, and you could receive secondary injuries by a fall against a live circuit or from a ladder to the ground.
 - Set meter to the correct mode and voltage range. If possible check its operation on a 120 volt convenience outlet. Multi-range instruments should always be set to their maximum voltage range when not in use.
 - Use a single-function meter (voltmeter) rather than a multi-meter, if possible
 - The meter case should be heavy enough to indicate significant amount of insulation. The case should be large enough to enclose non-arcing 600v fuses in the current measurement input circuit. Measurement ranges should be unambiguously marked.
 - Check insulation on the instrument leads is in good condition. If they are not the original leads, make sure that they are rated at 1000 volts or more
 - Use only a minimum of exposed metal at the prod tips to avoid short circuiting closely spaced live parts, don't use bare alligator clips.

- Where possible, test on the load side of the fuse or circuit breaker having the smallest rating
- Always be sure your portable tools are grounded through a three prong plug or double insulation. Tools should be checked before using for internal shorts. Circuits used should be protected by a GFCI
- When working on a circuit be sure to lock open the supply disconnect switch. It should be tagged to make sure nobody tries to close it
- Beware of grounded 480v circuits. The first ground on such system will not cause the over-current protection to trip. The second ground will, but, at the points of the ground a dangerous flash will occur. Know the type of circuit you are working on



R. LITZ & SONS Co. Ltd. www.litzcranes.com

277 McPhillips St.
Winnipeg, Mb. R3E 2K7
Ph: (204) 783-7979
Fax: (204) 775-3250
Toll free: 1-888-CRANE03



info@litzcranes.com

CRANE & RIGGING 'SERVING INDUSTRY SINCE 1903'

SWP – Explosive Actuated Fastening Tool Use

There are a number of tools utilizing an explosive charge in use throughout the construction industry to drive in fasteners. The manufacturers of these devices provide detailed instructions regarding their use and maintenance. These instructions, along with the legislation specifically set out for their use, shall be closely adhered to at all times.

The following general recommendations apply to all explosive/powder actuated tools.

- Only properly trained and qualified operators are to use this type of tool. The user shall possess proof of this training issued by the manufacturer, authorized dealer/distributor, or other competent source
- The tool must be CSA standard approved for “explosive actuated fastening tools”
- Tools should never be loaded and then left to sit or be moved to an alternate work site. The tool should be loaded just before use with the correct load for the job anticipated
- The tool should never be pointed at anyone, whether loaded or unloaded. Hands should be kept clear of the muzzle end at all times
- Explosive actuated tools should always be stored in their proper lockable boxes
- Explosive actuated tools must never be used in an explosive atmosphere
- When used, the tool must be held firmly and at right angles to the surface being driven into
- Eye protection must be worn by the operator. Where there is a danger of spalling, full face protection must be worn. Hearing protection is also to be worn in confined areas.
- To prevent free-flying studs, ensure that the material being driven, into will not allow the stud to completely pass through it (i.e., glass block, hollow tile, etc.)

LITZ
CRANE & RIGGING

R. LITZ & SONS Co. Ltd. www.litzcranes.com
277 McPhillips St.
Winnipeg, Mb. R3E 2K7
Ph: (204) 783-7979
Fax: (204) 775-3250
Toll free: 1-888-CRANE03

MEMBER
SC&RA
info@litzcranes.com

'SERVING INDUSTRY SINCE 1903'



SWP – Extension Cords Portable

- All portable extension cords must be of the outdoor type, rated 600v and have an insulated grounding conductor. The rated load shall not be exceeded.
- Defective cords must not be used
- Extension cords are to be protected during use to prevent damage from sharp edges, movement of materials, flame cutting and other operations
- Extension cords shall not be fastened with staples, hung from nails or suspended by wire
- Extension cords used in hazardous area such as metal enclosures or damp locations should be equipped with approved ground fault protection

LITZ

CRANE & RIGGING

R. LITZ & SONS Co. Ltd. www.litzcranes.com

277 McPhillips St.
Winnipeg, Mb. R3E 2K7
Ph: (204) 783-7979
Fax: (204) 775-3250

Toll free: 1-888-CRANE03



info@litzcranes.com

'SERVING INDUSTRY SINCE 1903'

SWP - Extension Ladder

With the right ladder and proper use, working above ground level should be no problem. Make sure you have an appropriate ladder and use correct technique for placement and climbing.

Do's

- Do wear appropriate PPE
- Stay mindful of the 1 measure out to 4 measure up rule
- Inspect ladder prior to each use
- Follow the proper ladder set-up procedure
- Securely engage ladder locks before climbing
- Maintain 3 point contact
- Tie the ladder off
- Always face ladder when climbing
- Look overhead before placing a ladder
- Do set up ladder on ground floor and on a stable surface
- Keep your belt buckle between the rails
- Have at least 3 steps above the top contact point

Don'ts

- Set up ladder so it is resting on rungs
- Leave ladders set up and unattended
- Use Ladders if you tire easily
- Go up and down ladders backwards
- Use ladders in high winds
- Do not overload ladders
- Don't walk or shift a ladder while standing on it
- Use aluminum or wood ladders when working around electricity
- Carry heavy objects or tools up the ladder
- Never set-up a ladder on any platform that is elevated

LITZ

CRANE & RIGGING

R. LITZ & SONS Co. Ltd. www.litzcranes.com

277 McPhillips St.
Winnipeg, Mb. R3E 2K7
Ph: (204) 783-7979
Fax: (204) 775-3250

Toll free: 1-888-CRANE03



info@litzcranes.com

'SERVING INDUSTRY SINCE 1903"

SWP – Working in Extreme Temperature

Cold Weather

Do's

- Monitor yourself and your co-workers
- Take frequent breaks in warm dry shelters
- Drink fluids, warm sweet drinks
- Wear lightweight clothing
- Dress warmly and stay dry
- Avoid over-exertion
- Be cautious about travel take extra precautions
- Recognize weather changes
- Be aware of the effects of cold weather
- Schedule outdoor work for the warmest part of the day
- Wear a hat 40% of body heat is lost through the head
- Wear sunglasses to prevent snow blindness

Don'ts

- Consume drinks with caffeine they can cause dehydration
- Allow clothing to become damp
- Be unprepared for weather situations
- Don't bathe just before going outside
- Don't consume alcohol

Warm Weather

Do's

- Drink Plenty of water to keep body fluid levels up
- Be alert to early warning signs of heat stress for you and your co-workers
- Slow down in hot weather. Your body's temperature regulating system faces a much greater workload when temperature and humidity are high.
- Dress for hot weather. Lightweight, light-colour clothing reflects heat
- Increase your salt intake, preferably by adding salt to your food. (Consult your physician if you are on a salt-restricted diet.)
- Get out of the heat occasionally. Physical stress increases with time in hot weather. Take breaks in a cool, shady location.
- Try to get used to warm weather gradually. Take it easy for those first two or three hot days. Your body will have a better chance to adjust if you take it slow.
- Wear a hat with a wide brim to shade the face, head, ears, and neck.

Don'ts

- Ignore symptoms of heat stress
- Don't try to get a suntan while you are working! It's harder for your internal cooling system to work through sunburned skin. Wear a hat and long-sleeved shirt to prevent burning (which we know can increase the risk of skin cancer.)
- Try to "keep up" with the rest of the crew, even though you feel ill.

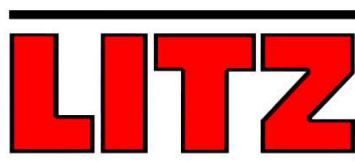

CRANE & RIGGING

R. LITZ & SONS Co. Ltd. www.litzcranes.com

277 McPhillips St.
Winnipeg, Mb. R3E 2K7
Ph: (204) 783-7979
Fax: (204) 775-3250

Toll free: 1-888-CRANE03



info@litzcranes.com

'SERVING INDUSTRY SINCE 1903'

SWP – Fire Precautions

The following precautionary measures will keep fire losses to a minimum:

1. Good housekeeping tends to remove fire sources and provides easier control when emergencies arise. Make a daily check to eliminate any accumulation of rubbish, oily rags, combustible scrap etc.
2. Never attempt to start fires in stoves, salamanders etc. with gasoline, kerosene or any other flammable liquid, never pour a flammable liquid on a fire that is already burning
3. Make a periodic check on the wiring and connections in all tool rooms, construction buildings, office, etc.
4. All clothing must be kept to a minimum of three feet from the nearest edge of the stove
5. Instruct all personnel to make a thorough inspection of their work clothing at the end of the shift so as to locate and remove any hot slag, molten metal, etc.
6. Clothing that is soiled with oil, grease, or paint should not be left in confined places but should be hung out in the open air
7. Never store paint, oil lubricants, or other highly flammable materials in heated fabrication buildings, Keep such material in a separate building isolated somewhat from other buildings, Establish a definite procedure for handling flammable liquids
8. Prohibit smoking in highly flammable areas. Provide limited smoking areas if necessary
9. Instruct as many of the personnel as possible, particularly key employees and security guards, in the proper use of fire- fighting equipment
10. Establish regular inspections to detect fire hazards and take immediate corrective action upon detection of such a hazard
11. Establish a regular schedule for servicing and maintaining fire extinguishers as the job progresses. Remember that water extinguishers must be protected with anti-freeze solutions in winter weather
12. Be certain that key personnel know the location of the nearest fire alarm and are familiar with the method of sounding such an alarm
13. Before starting any burning or welding, look around to make certain that flames sparks or hot metal will not be likely to start a fire. Remember that fires resulting from this type of work are often delayed in starting. Inspect the area thoroughly after the operation is complete.

14. A suitable fire extinguisher should always be ready for instant use where welding or burning is done. Where combustible materials are present near the operation, a helper or extra work, if necessary should be on hand to guard against fires.
15. One approved fire extinguisher, in good condition must be in place on each crane
16. Never attempt to fuel any equipment while it is in operation or the engine is running. Avoid spilling fuel on a hot engine
17. When working in highly flammable areas it is necessary to contain the sparks from exhaust on engines
18. Remember that the first few seconds are important, a few seconds saved at the start of a fire may make the difference between something comparatively minor and a major loss
19. Provide any special fire-fighting equipment required by conditions, owner requirements, etc. water barrels, fire hose on water trucks hose carts, fire trucks, stand pipe systems, asbestos clothing, self contained breathing apparatus, etc.
20. Instruct personnel to call the nearest fire department immediately. Post telephone numbers of fire departments at each telephone location
21. When flammable liquids are handled or used in small containers such as five gallon cans, such cans must be of an approved safety type, painted red in color, with yellow wording stating "DANGER KEEP AWAY FROM FIRES" and listing the contents

LITZ CRANE & RIGGING **R. LITZ & SONS Co. Ltd.** www.litzcranes.com
277 McPhillips St.
Winnipeg, Mb. R3E 2K7
Ph: (204) 783-7979
Fax: (204) 775-3250
Toll free: 1-888-CRANE03
MEMBER **SC&RA**
info@litzcranes.com
'SERVING INDUSTRY SINCE 1903'

SWP – First Aid for Chemicals

Flushing

How long should the skin or eyes be flushed with water in the event of a chemical exposure?

- 5 minutes for non-irritants or mild irritants
- 15-20 minutes for moderate to severe irritants and chemical that cause acute toxicity if absorbed through the skin,
- 30 minutes for most corrosives and
- 60 minutes for strong alkalis (e.g. sodium, potassium or calcium hydroxide)

Flushing water should start immediately following skin or eye contact with a chemical. It is best to complete water flushing on-site. However moving the victim to an emergency care facility earlier may be necessary depending on the victim's condition.

Oxygen Administration

Oxygen should be administered as a first aid measure after any chemical exposure through inhalation. It was previously thought that oxygen could worsen some medical conditions, however this has been found to be untrue and the lack of oxygen is the main focus. There are many risks associated with oxygen storage such as fire hazards, these risks must be taken into consideration prior to storage and use.

Emergency oxygen may be beneficial following exposure to chemicals that interfere with the body getting the necessary levels of oxygen to sustain life and health, including chemicals that:

- Displace oxygen in the air, reducing the amount of oxygen available for breathing (e.g. helium, argon, methane, carbon dioxide or nitrogen).

- Reduce the ability of blood to transport oxygen (e.g. carbon monoxide poisoning, or methemoglobinemia)
- Compromise the use of oxygen by body tissue, as with cyanide or hydrogen sulphide toxicity
- Interfere with the ability of oxygen to cross through the lungs to the blood stream, as occurs with pulmonary edema,
- Provoke a severe asthma attack

Vomiting

Evidence and commons sense indicate that inducing vomiting is NOT necessary in most situations where there has been an occupational chemical ingestion. Some of the arguments against inducing vomiting are:

- The amount of chemical accidentally ingested by an adult is generally estimated to be very small (14-21 ml or about 0.5-0.75 oz.)
- There is no conclusive evidence that victims of chemical ingestion who do have their stomachs emptied have more successful outcomes than victims who do not
- There can be significant risks associated with inducing vomiting especially in emergency situations
- There does not seem to be a reliable and safe first aid procedure for inducing vomiting in adults
- Medical attention is usually available quite quickly in most situations

In the event of a chemical ingestion, the best course of action is to call your local Poison Control Centre or a doctor and follow their advice.

*****YOU SHOULD NOT AUTOMATICALLY ASSUME THAT YOU SHOULD INDUCE VOMITING IN SOMEONE WHO HAS INGESTED A CHEMICAL*****

How to know which first aid procedure to follow for chemicals in the workplace

In order to know what first aid procedures to follow, it is essential that you know what chemicals are present in your workplace. Consult your chemical inventory and the first aid measures section on the material safety data sheets. Create a list of chemicals, their properties and their corresponding first aid requirements.

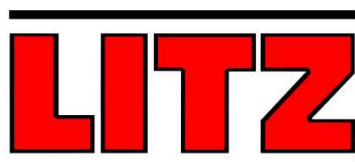

CRANE & RIGGING

R. LITZ & SONS Co. Ltd. www.litzcranes.com

277 McPhillips St.
Winnipeg, Mb. R3E 2K7
Ph: (204) 783-7979
Fax: (204) 775-3250

Toll free: 1-888-CRANE03



info@litzcranes.com

'SERVING INDUSTRY SINCE 1903'

SWP – First Aid

1. Report all injuries, no matter how minor, to your foreman or to first aid as soon as possible
2. Know the location of the job site first aid facilities and/or first aid kits. Get treatment for injuries as soon as possible
3. Never move an injured person unless that person is at risk of further injury
4. Any injury where the skin is broken(i.e. laceration, cuts, punctures, etc.) must be carefully treated so as to avoid infection, don't wait
5. If you are injured, or if you are assisting someone who has been injured, do not become overly excited. Great haste in applying first aid is often not necessary and can sometimes be harmful
6. In most cases of severe bleeding, the first thing to do is apply the cleanest padding available directly to the wound, keeping firm pressure on it until help can take over. The possibility of a fractured skull is the exception to this rule.
7. Most serious injuries involve shock. Provide warm covering to the injured worker(blankets jacket, etc) Do not give the injured anything to drink use a damp cloth to keep the lips moist
8. When chemicals contact the skin, washing with large amounts of water, for at least 15 to 20 minutes, is imperative. If fumes, vapours or dusts are inhaled, removing the victim to fresh air will provide the most benefit until help arrives
9. In cases where breathing has stopped, artificial respiration or mouth to mouth breathing must be started immediately. Only those persons properly trained in artificial respiration should attempt to do this

Remember

- Call for help immediately
- Stop severe bleeding
- Restore breathing
- Avoid panic
- Inspire confidence
- Do no more than is necessary until help arrives

LITZ

CRANE & RIGGING

R. LITZ & SONS Co. Ltd. www.litzcranes.com

277 McPhillips St.
Winnipeg, Mb. R3E 2K7
Ph: (204) 783-7979
Fax: (204) 775-3250

Toll free: 1-888-CRANE03



info@litzcranes.com

'SERVING INDUSTRY SINCE 1903'

SWP – Flammable Liquids

Flammable Liquid use is common place in almost all industries, they are readily used in mechanics shops, in the field and personally in the home.

Do's

- Wear proper PPE when handling flammable liquids
- Keep flammable liquids in approved safety containers
- Keep away from ignition and heat sources
- Label containers appropriately
- Know and understand the M.S.D.S for each product
- Be aware of the signs of exposure to flammable liquids such as dizziness, vomiting, mental confusion, giddiness, etc.
- Be aware that with temperature increase the vapours produced by flammable liquids increase
- Keep all flammable liquids when not in use in a metal flammables cabinet
- Keep an appropriate fire extinguisher nearby when using or storing flammable liquids
- Ensure proper ventilation for flammable liquids

Don'ts

- Smoke or use flammable liquids near fires
- Store flammable liquids near exits, principle routes that provide access to exits, and near products with which they are known to react
- Leave flammable liquids lying around improperly stored
- Dump flammable liquids down sinks or in sewer drains
- Do not leave flammable liquid containers open when not in use

LITZ

CRANE & RIGGING

R. LITZ & SONS Co. Ltd. www.litzcranes.com

277 McPhillips St.
Winnipeg, Mb. R3E 2K7
Ph: (204) 783-7979
Fax: (204) 775-3250

Toll free: 1-888-CRANE03



info@litzcranes.com



'SERVING INDUSTRY SINCE 1903'

Grinders Portable

General

An abrasive wheel can break and cause severe injury. Proper storage of new wheels, proper use of wheels and proper maintenance of wheels must be observed.

Familiarize yourself with the grinder operation before commencing work.

- Guards must be provided in place and adjusted to protect you. Replace any damaged guards
- Clean and service grinders, according to manufacturer's recommendations. Record all maintenance for grinders
- Ensure that a machine will not operate when unattended by checking dead-man (constant pressure) switch
- Wear safety glasses, goggles, and full face shield, to protect against flying particles. Gloves, aprons, approved safety boots and respiratory protection are advisable depending on work

Speeds

- Maximum speed in revolutions per minute (rpm) is marked on every wheel. Never exceed this speed
- Check the speed marked on the wheel; compare it to the speed on the grinder. Make sure it is equal to or greater than the speed marked on the grinder.
- Measure speed of any new machine. Take several readings
- Measure speed of governor controlled air driven grinders after 20 hrs of use, every week, whichever comes first. Measure speed after any repairs
- Measure speed of electrically driven grinders

LITZ

CRANE & RIGGING

R. LITZ & SONS Co. Ltd. www.litzcranes.com

277 McPhillips St.
Winnipeg, Mb. R3E 2K7
Ph: (204) 783-7979
Fax: (204) 775-3250

Toll free: 1-888-CRANE03



info@litzcranes.com



'SERVING INDUSTRY SINCE 1903'

Grinding

General

- Check the tool rest for the correct distance from the abrasive wheel, maximum of 1/8" or 3mm
- Replace the grindstone when adjustment of the rest cannot provide 1/8" or 3 mm clearance
- If the wheel has been abused and ground to an angle or grooved, replace the wheel with the appropriate surfacing tool
- Protect your eyes with goggles and a face shield at all times when grinding
- Each time a grinding wheel is mounted, the maximum approved speed stamped on the wheel bladder should be checked against the shaft rotation speed of the machine to ensure the safe peripheral speed is not exceeded. A grinding wheel must not be operated at peripheral speed exceeding the manufacturers recommendation
- The flanges supporting the grinding wheel should be a maximum of 1/3 the diameter of the wheel and must fit the shaft rotating speed according to the manufacturers recommendation
- Bench grinders are designed for peripheral grinding. Do not grind on the side of the wheel
- Do not stand directly in front of the grinding wheel when it is first started

LITZ
CRANE & RIGGING

R. LITZ & SONS Co. Ltd. www.litzcranes.com
277 McPhillips St.
Winnipeg, Mb. R3E 2K7
Ph: (204) 783-7979
Fax: (204) 775-3250
Toll free: 1-888-CRANE03

MEMBER
SC&RA
info@litzcranes.com

'SERVING INDUSTRY SINCE 1903'

SWP – Guardrails

1. The sub-trades will be responsible for ensuring all guardrails are to OH&S standards for the specific location
2. Guardrails must be installed wherever there is a hazard of falling 4 feet or more from a permanent level or 10 feet or more from a temporary level.
3. Guardrails must have top rails, mid rails and toe boards that meet OH&S standards specific to the location
4. Where fall prevention devices must be removed for work to proceed, permission to remove them must be obtained from the job supervisor. When fall protection/prevention devices are temporarily removed. Workers must be protected by full fall arresting equipment
5. Guardrails and barricades that have been temporarily removed must be replaced as quickly as possible
6. In some cases where it is impracticable to use fall prevention devices such as guardrails full fall arresting equipment must be used

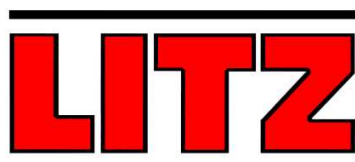

CRANE & RIGGING

R. LITZ & SONS Co. Ltd. www.litzcranes.com

277 McPhillips St.
Winnipeg, Mb. R3E 2K7
Ph: (204) 783-7979
Fax: (204) 775-3250

Toll free: 1-888-CRANE03



info@litzcranes.com

'SERVING INDUSTRY SINCE 1903"

SWP - Hack Saw

Though the hacksaw is specially designed to cut through metal, it is often used to saw wood and plastic. And because of the unique frame design, the blade may be inserted both parallel and perpendicular to the frame, as shown in figure 4. The technique for using a hacksaw is identical to that of a crosscut saw.

Do's

- Wear all appropriate PPE
- Ensure work area is clear of all obstructions
- Place the 24 -teeth-per-inch blade onto the forward and rear pins so teeth are facing away from handle.
- Use the entire length of the blade when cutting material
- Make sure to turn the wing nut so that blade is secure in frame. To operate effectively, blade must be under tension at all times.
- Ensure pipe is secure in vise, one end protruding a few inches.
- Do grasp the hacksaw handle firmly
- Keep cuts close to the vise, there will be fewer vibrations and a more accurate cut.
- Take long, easy strokes over the pipe until a groove is formed.
- Exerting additional, but not excessive pressure while making the cut.
- If cutting becomes difficult, apply a few drops of lubricating oil to the blade.
- Relieve pressure before cutting through the pipe.
- Watch your toes when the pipe end falls to the floor
- Do not twist blade and exert too much pressure, as this will break the blade

REPORT ALL HAZARDOUS SITUATIONS TO YOUR SUPERVISOR

Don'ts

- Loose focus while cutting
- Cut cable or pipe on leg or use leg as support for cutting
- Don't twist or over reach
- Use the wrong blade for the material being cut
- Have long hair untied or loose clothing so saw can get caught
- Use short rapid strokes

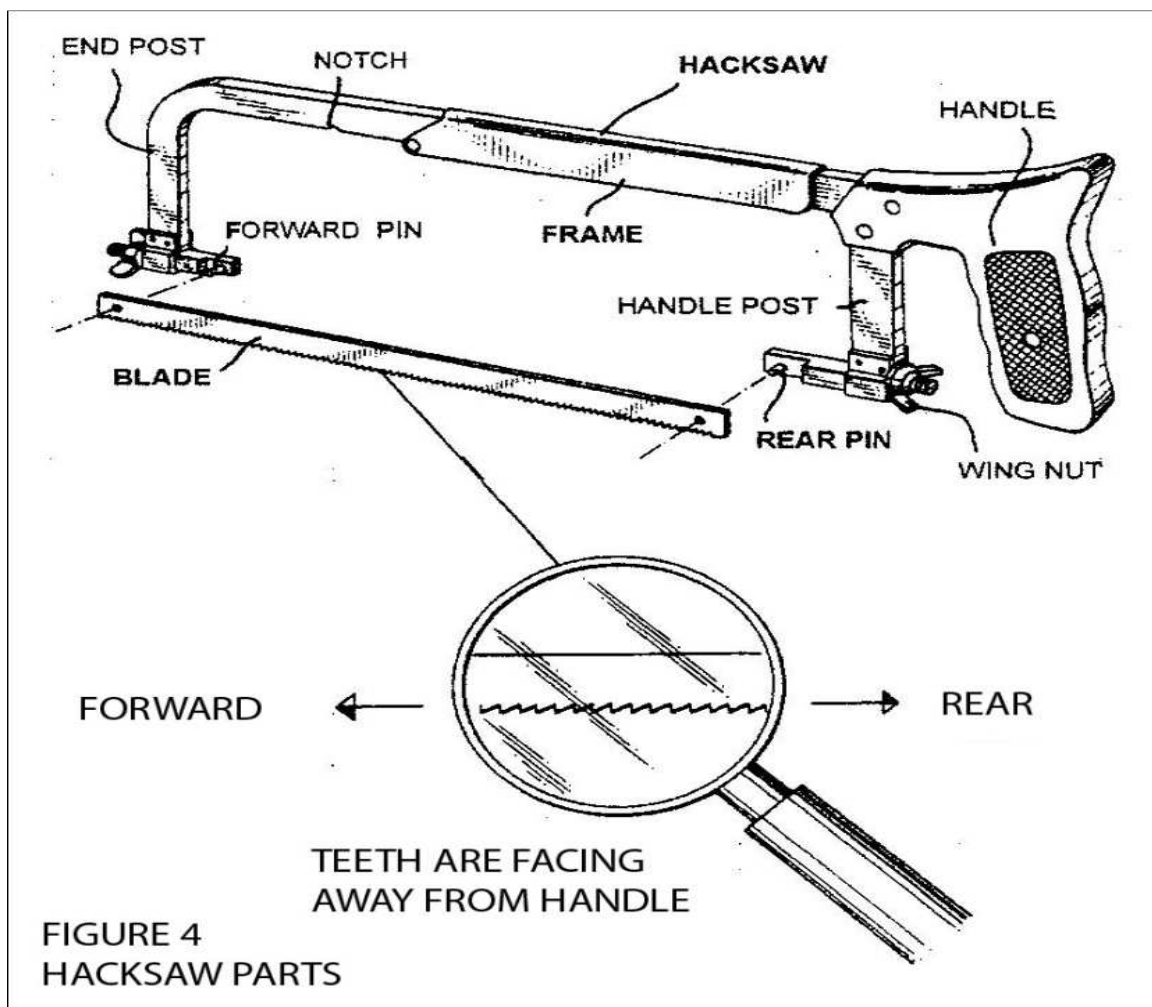

REPORT ALL HAZARDOUS SITUATIONS TO YOUR SUPERVISOR

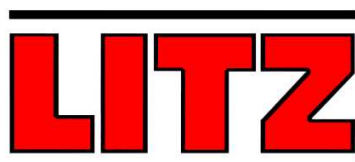

CRANE & RIGGING

R. LITZ & SONS Co. Ltd. www.litzcranes.com

277 McPhillips St.
Winnipeg, Mb. R3E 2K7
Ph: (204) 783-7979
Fax: (204) 775-3250

Toll free: 1-888-CRANE03



info@litzcranes.com

'SERVING INDUSTRY SINCE 1903'

SWP – Hand Saw Safety

According to U.S. Consumer Product Safety Commission data approximately 3,500 people nationwide received hospital treatment for hand-saw injuries in 2004. Of this total about 1,300 of the injuries involved lacerations to fingers and hands. Other injuries included finger fractures and amputations hand fractures, wrist arm, and leg lacerations, and sprains to the lower back and trunk. The majority of these hand-saw injuries were due to operator error or inattention.

Hand Saw precautions

- Prior to use, inspect hand saws for defects such as splintered or cracked handles missing saw-blade teeth, loose saw blade connections, and bent saw blade or frame handles
- Any saw with defects shall be removed from service by attaching a red tag that states "Do Not Use" complete red tag with appropriate information and notify your supervisor
- Always wear eye protection when using a hand saw
- Do not test saw teeth on hands or fingers to determine whether a hand saw is sharp
- Use proper type of hand saw for the material to be cut or type of cut to be made. For example use a ripping hand saw for cutting along the grain of the wood and a cross-cut hand saw for cutting across the grain of the wood
- Select the correct type of hacksaw blade for the type of material to be cut
- When preparing to cut wood, inspect the wood stock for nails or other imbedded objects that could damage the hand saw
- Begin cutting by starting carefully and slowly to prevent the saw blade from jumping or binding
- When using a pruning hand-saw, do not cut limbs or branches above your head and use your free hand to hold the limb or branch while sawing
- Place stock in vice or hold stock firmly when sawing. Use a helper or bench to support long stock
- Use the length of the blade during each saw stroke
- Always carry a hand saw by its handle with the saw end pointed down keep all hand saw blades sharp and clean. Also keep hacksaw blades lightly oiled
- When finished with the had saw return it to its assigned storage place



R. LITZ & SONS Co. Ltd. www.litzcranes.com

277 McPhillips St.
Winnipeg, Mb. R3E 2K7
Ph: (204) 783-7979
Fax: (204) 775-3250
Toll free: 1-888-CRANE03



MEMBER
SC&RA
info@litzcranes.com

CRANE & RIGGING 'SERVING INDUSTRY SINCE 1903'

Hazardous Material Precautions

1. Be aware of containers with unknown/unlabeled substances. Accidentally mixing waste materials could cause a chemical reaction resulting in fire, explosion, or atmospheric release of toxic vapours. Be alert for build up, vapours, rumbling noise, etc. In such cases, stop work, vacate the area and notify supervisor
2. Be familiar with the specific plans and other related rules/guidelines for handling hazardous waste materials. Notify the supervisor if a hazardous substance is spilled. Use proper procedure for clean up, including the use of personal protective equipment.
3. Material handling equipment (forklifts, trucks, etc.) shall be operated in a safe manner, as established in applicable training programs and manufacturers guidelines. The moving of heavy containers could result in punctures. Be alert for leaks, dampness unusual debris and strange odours caused by airborne contaminants.
4. Posted M.S.D.S should be read and complied with
5. Operate oil/water separator only with approval for supervisor
6. Frequently check pressurized hoses and piping for leaks
7. Frequently check all locking straps and load securing devices before and after transport
8. Proper lifting techniques shall be used. Get help when using lifting equipment if necessary
9. If entry into a confined space is necessary, confined space entry safe work procedure must be followed. Area must be treated as a high hazard confined space entry. Never enter a confined space without a standby observer
10. Be aware of fire extinguishers, alarm and hose locations. Check routinely to make sure they are working properly. Follow good housekeeping practices to reduce the risk of fires.
11. Be aware of loose or slippery materials, tripping hazards and other obstructions. Take appropriate measures to eliminate them
12. Properly trained personnel should only handle hazardous materials
13. Be familiar with local emergency numbers



R. LITZ & SONS Co. Ltd. www.litzcranes.com

277 McPhillips St.
Winnipeg, Mb. R3E 2K7
Ph: (204) 783-7979
Fax: (204) 775-3250
Toll free: 1-888-CRANE03



info@litzcranes.com

'SERVING INDUSTRY SINCE 1903'

SWP – High Voltage Lines

Minimum Clearance

- a. No worker shall be employed, no material shall be piled, stored or otherwise handled nor scaffolding erected or dismantled, nor tools, machinery on equipment operated within the specified minimum distances from any energized high voltage electrical equipment, unless workers are protected in accordance with this section.

- b. The following minimum distances shall be maintained:

Voltage (Phase to Phase)	Minimum Distance Feet (meters)
751v-75kv	10(3)
Over 75kv-250kv	15(4.6)
Over 250kv-550kv	20(6.1)

- c. Overhead Electrical lines

Where overhead electrical conductors are encountered in proximity to a work area the employer shall be responsible for:

- Ascertaining the voltage and minimum clearance distance required and
- Maintaining the minimum clearance, and
- Ensuring that the requirements of clause (a) are complied with

Low Voltage Lines

When work is being carried out in proximity to energized electrical conductors operating at 750v or less, such work shall be performed in a manner to prevent contact by any worker with the energized conductors

LITZ

CRANE & RIGGING

R. LITZ & SONS Co. Ltd. www.litzcranes.com

277 McPhillips St.
Winnipeg, Mb. R3E 2K7
Ph: (204) 783-7979
Fax: (204) 775-3250

Toll free: 1-888-CRANE03



info@litzcranes.com

'SERVING INDUSTRY SINCE 1903'

SWP - Hoisting Personnel

Do's

- Inform Workplace Health and Safety and attain their approval prior to hoisting personnel with a crane
- Ensure all man baskets and working platforms are manufactured and maintained in accordance with government regulations
- Always lower/raise personnel "power up/down" in a suspended working platform or basket at a comfortable speed. A comfortable speed is defined as a speed which does not cause discomfort to the occupants of the basket while in motion and also causes minimal discomfort should the basket be stopped suddenly

Don'ts

- No person is to ride on a load, the hook, the block, the boom or any other hoisting apparatus not specifically designed and certified for hoisting personnel.
- No person hoisted in a suspended or fixed working platform or basket will tie their person off to the man basket or platform. All hoisted persons will tie themselves off to the structure of the crane itself, the hook or block of the crane or some other structure specifically engineered and approved for such a purpose.
- No person hoisted in a suspended or fixed working platform or basket will use the frame of the man basket or platform as a "dead-man"
- No operator shall hoist personnel on a bosom chair or similar device
- Personnel shall never be "free felled" in a suspended working platform or basket.
- No person shall be hoisted in a suspended or fixed working platform or basket without that person being properly secured with an approved life lanyard and harness
- No person is to climb out of a suspended or fixed working platform or basket during hoisting operations.

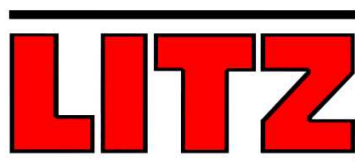

CRANE & RIGGING

R. LITZ & SONS Co. Ltd. www.litzcranes.com

277 McPhillips St.
Winnipeg, Mb. R3E 2K7
Ph: (204) 783-7979
Fax: (204) 775-3250

Toll free: 1-888-CRANE03



info@litzcranes.com

'SERVING INDUSTRY SINCE 1903'

SWP – Hot Work

Employees must wear hard hats, safety glasses, face shields, hot gloves, flame retardant coveralls and respiratory protection as required and a fire extinguisher must be kept in close proximity

A step-by-step plan for the work for that day shall be completed, this plan will cover in detail, equipment and personnel needs, obtaining notifications and approvals, gaining access to the energized equipment, verifying what parts may be energized, completing the work, returning the equipment to the original configuration and revoking the approvals and notifications.

This plan shall be discussed in detail with other qualified persons

- Cutting and welding operations restricted to authorized, properly trained individuals;
- Do not work alone on energized equipment except where safe work procedures have been established and approved
- Obtain approvals for the work, using site-standard forms and notify all groups who may be affected by the work
- Take into account ambient conditions such as rain, humidity, and height from the ground, etc.
- Clients shall have an extra trained and qualified person available for safety purposes
- Use equipment and system drawings to confirm which parts are to be worked on. Check meters for safe conditions and correct range before starting the work
- Voltage must be tested before touching or grounding any electrical equipment
- If possible, hot work performed in a properly designed shop area equipped with all necessary controls and adequate ventilation;
- Move combustible materials at least 35 feet from the work site. If this is not possible, protect combustible materials with metal guards or by flameproof curtains or covers (other than ordinary tarpaulins);
- Cover floor and wall openings within 35 feet of the work site to prevent hot sparks from entering walls or falling beneath floors or to a lower level;

- Fire resistant curtains and /or tinted shields used to prevent fire, employee burns, and ultra-violet light exposure.
- After all work has been completed and systems are returned to normal, the approval form shall be returned and the relevant groups notified
- If after all work has been completed and the system cannot be returned to its normal configuration, the equipment should be tagged with a warning and explanatory sign and physical access should be prevented

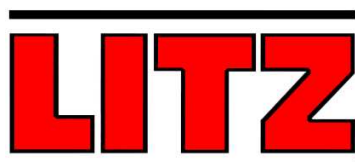

CRANE & RIGGING

R. LITZ & SONS Co. Ltd. www.litzcranes.com

277 McPhillips St.
Winnipeg, Mb. R3E 2K7
Ph: (204) 783-7979
Fax: (204) 775-3250

Toll free: 1-888-CRANE03



info@litzcranes.com

'SERVING INDUSTRY SINCE 1903'

SWP – Hypothermia

General

Hypothermia is a year round hazard. It can result from exposure to the elements in cold northern winters, but is most frequently associated with the sudden immersion in icy lakes or streams in warmer seasons. Those whose work often has them over water may forget that many lakes and streams remain cold the whole year round.

Hypothermia describes the rapid, progressive mental and physical collapse accompanying the chilling of the inner core of the human body. Hypothermia is caused by exposure to cold, aggravated by wet wind and exhaustion. It is the #3 killer of outdoor recreationists

- DO take heed of “hypothermia weather”
- DO watch carefully for warming symptoms
- DO choose equipment with hypothermia in mind

Cold kills in 2 ways:

1. Exposure & Exhaustion

The moment the body begins to lose heat faster than it produced it, you are undergoing exposure. Two things happen a) you voluntarily exercise to stay warm; b) the body makes involuntary adjustments to preserve normal temperature in the vital organs. Either response drains energy resources. The only way to stop the drain is to reduce the degree of exposure.

THE TIME TO PREVENT HYPOTHERMIA IS DURING THE PERIOD OF EXPOSURE AND GRADUAL EXHAUSTION

2. Hypothermia

If exposure continues until energy reserves are exhausted:

- Cold reaches the brain depriving a person of judgement and reasoning power. The victim will not realize what is happening
- The victim will lose control of the hands
- This is hypothermia. The internal body temperature is sliding downward. Without treatment this slide leads to stupor, collapse and death
- Don't underestimate cold – Most hypothermia cases develop in air temperatures between 30° and 50° Fahrenheit water 50° degrees Fahrenheit is unbearably cold
- Use your clothes – put on rain gear before you get wet. Put on wool clothes before you start shivering



R. LITZ & SONS Co. Ltd. www.litzcranes.com

277 McPhillips St.
Winnipeg, Mb. R3E 2K7
Ph: (204) 783-7979
Fax: (204) 775-3250
Toll free: 1-888-CRANE03



info@litzcranes.com

CRANE & RIGGING 'SERVING INDUSTRY SINCE 1903'

SWP - Illumination & Fixed Temporary Lighting

Where natural illumination is not sufficient artificial lighting shall be used

Temporary lighting (except battery powered) shall be protected with approved guards

1. All areas where workers must work, pass through, or be presented including areas of access and egress, must be adequately illuminated.
2. Suggested construction levels:

General Construction work areas:	5 Foot Candles
Areas during concrete placement Excavation, field maintenance, and refuelling of vehicles and equipment	3 Foot Candles
Access ways:	3 Foot Candles
Active storage areas, waste storage Areas, and loading platforms	5 Foot Candles

3. Missing or burned out light bulbs must be replaced
4. Dark areas are not to be entered without the assistance of portable lighting or flashlights

LITZ
CRANE & RIGGING

R. LITZ & SONS Co. Ltd. www.litzcranes.com
277 McPhillips St.
Winnipeg, Mb. R3E 2K7
Ph: (204) 783-7979
Fax: (204) 775-3250
Toll free: 1-888-CRANE03

MEMBER
SC&RA
info@litzcranes.com

'SERVING INDUSTRY SINCE 1903'



SWP – Proper Labelling

Containers must have labels that:

- Must include the name of the chemical
- The hazards associated with the chemical
- Name of the manufacturer or distributor
- Any body part or organ that can possibly be affected by the use of the product or chemical.

** If placing a product or chemical in a secondary container, unless for single use, the above information must be included on any new container**

All hazardous products in the work place must have an M.S.D.S sheet that contains:

- The above information
- Route of entry
- Physical or health hazard
- First aid procedures
- All chemicals that have had an M.S.D.S for them must remain in the inventory list of hazardous chemicals for 30 years.

LITZ

CRANE & RIGGING

R. LITZ & SONS Co. Ltd. www.litzcranes.com

277 McPhillips St.
Winnipeg, Mb. R3E 2K7
Ph: (204) 783-7979
Fax: (204) 775-3250

Toll free: 1-888-CRANE03



info@litzcranes.com

'SERVING INDUSTRY SINCE 1903'

SWP - Ladders – Extension Safety

Do's

- Check for overhead electrical wires before setting up
- Inspect ladders for defects prior to use
- Clear area around base and top of ladder of debris, tools and other objects
- Tie yourself off using a safety harness if you are working 3 metres or 10 feet or more above ground, or when working with both hands
- Ensure that only one person is on a single-width ladder, only one person is allowed on each side of a double width ladder
- Maintain 3 point contact by keeping 2 hands and 1 foot or 2 feet and 1 hand in contact with the ladder at all times
- Grasp rungs firmly when climbing ladder, not the side rails. If your foot slips on ladder it is easier to hold onto a rung than onto the side rails
- Wear safety boots with slip resistant soles and heels
- Ensure that all electrical equipment used during ladder work is in good condition and properly grounded
- Take frequent rests to avoid arm fatigue and disorientation when the work performed demands reaching and looking up above your head
- Place ladder feet $\frac{1}{4}$ of ladder's working length away from the base of the structure or use the 1 foot out for every four feet up rule
- Erect ladder so that a minimum of 1m (3 ft) extends above landing platform. Tie top at support points
- Erect extension ladder so that the upper section rests on the bottom section
- Place ladder on a firm level surface and ensure a secure footing
- Maintain the minimum overlap of sections as shown on ladder label refer to safety regulations

If you become dizzy or panicky rest your head against another rung or side rail when you feel safe to do so climb down slowly

Do Not's

- Do Not use ladder near electrical wires
- Do Not splice together short ladders to make a longer ladder, the side rails are not strong enough to support the extra load
- Do Not use ladders in passageways, doorways, driveways or other locations where a person or vehicle can hit it. Erect suitable barricades or lock doors shut
- Do Not place ladders against flexible or moveable surfaces
- Do Not Straddle the space between ladder and another object
- Do Not erect ladders on boxes, carts, tables or other unstable structures
- Do Not Stand ladder on any of its rungs, Ladder must rest on both side rails
- Do Not allow anyone to stand under ladder
- Do Not use ladder on ice
- Do Not over reach from ladder, move as required
- Do Not over extend maintain minimum overlap of sections
- Do Not climb higher than the fourth rung from the top of the ladder
- Do Not use ladder on ice, snow or slippery surface without securing ladder's feet
- Do Not extend top section of ladder from above or by "bouncing" on ladder

LITZ
CRANE & RIGGING

R. LITZ & SONS Co. Ltd. www.litzcranes.com
277 McPhillips St.
Winnipeg, Mb. R3E 2K7
Ph: (204) 783-7979
Fax: (204) 775-3250
Toll free: 1-888-CRANE03

MEMBER
SC&RA
info@litzcranes.com

'SERVING INDUSTRY SINCE 1903'



SWP - Ladders – Extension – Set Up

Extension Ladder Set Up Tips

- Lay ladder on the ground close to intended location
- Place the bottom of the ladder firmly against the base of a building or stationary object
- Lift the top of the ladder and pull upwards to raise ladder to a vertical position
- Brace ladder base using helpers feet
- Grasp the top rung with both hands, raise the top end over your head and walk towards the base of the ladder
- Grasp the centre of the rungs to maintain stability
- Move the erect ladder to the desired location, lean it forward against the resting point
- Transfer ladder to its required position when it is erect
- Keep ladder upright and close to the body with a firm grip
- Leave all tie-off devices in place until they must be removed
- Do Not raise or lower ladder when extended
- The method for lowering a ladder is the direct reverse procedure of erecting it

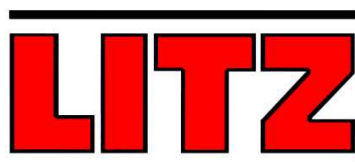

CRANE & RIGGING

R. LITZ & SONS Co. Ltd. www.litzcranes.com

277 McPhillips St.
Winnipeg, Mb. R3E 2K7
Ph: (204) 783-7979
Fax: (204) 775-3250

Toll free: 1-888-CRANE03



info@litzcranes.com

'SERVING INDUSTRY SINCE 1903"

SWP - Ladders – Portable Safety

Falls from ladders are one of the leading causes of serious injuries.

1. Only company approved ladders conforming to CAN3 Z11-M81 standards should be used
2. All ladders shall be inspected frequently and regularly. Ladders with weakened, broken or missing steps or rungs, cracked side rails, non-slip bases or other defects shall be tagged and removed from service until repaired or replaced
3. Wooden ladders shall not be painted, only a clear non-conductive finish such as boiled linseed oil or wood preservative shall be used
4. Aluminum, magnesium, other conductive metal ladders, wire, or wire reinforced wooden ladders shall not be permitted in energized switchyards, terminal stations, battery rooms, or where the possibility exists of the ladder or worker coming into contact with energized conductors or equipment
5. Ladders shall not be permitted in front of door openings unless the doorway is locked or guarded or unless suitable barricades have been erected
6. Ladders shall be set up on a firm level surface. If the base is to rest on soft un-compacted or rough soil, a mud sill should be used
7. When setting up a ladder, secure the base and “walk” the ladders up into place
8. All portable ladders shall be equipped with suitable non-slip safety feet or skid bases
9. Where there exists a hazard of the ladder slipping, it shall be securely held in place by tying or by a person holding the base of the ladder
10. The ladders should be set at the proper angle of 1 horizontal unit to every 4 vertical unit
11. Ladders shall not be climbed higher than the third step from the top

12. When dismounting from a ladder at an elevated position (roof) the employee shall ensure that the ladder extends at least one metre above the dismounted position
13. When ascending or descending ladders, employees shall use both hands for climbing and shall face the ladder. 3 points of contact shall be maintained at all times 2 feet and one hand or one foot and 2 hands
14. Only one employee shall be on a portable ladder at one time
15. Ladders shall not be used in an elevated horizontal position as substitutes for scaffold planks, runways or any other service unless specifically designed for that purpose
16. Workers on a ladder shall not straddle the space between a ladder and another object
17. Boxes, chairs, and tables are NOT ladders and shall not be used in place of ladders
18. Ladders shall not be erected on boxes, carts, tables, scaffold platforms, man lift platforms or on vehicles
19. Employees working from ladders at heights greater than 3 metres or whenever both hands must be used for the job or there exists a possibility of the employee falling from an elevated position they shall be belted in
20. Ladders not specifically designed for the purpose of splicing together, shall not be sliced in order to form a larger ladder
21. A ladder shall not be placed against an unsafe support. Rest both side rails on the top support with the top secured to prevent slipping
22. When sections of portable ladders are extended the overlap shall not be less than one metre. Do not remove safety extension bolts, or stopper bolts.

LITZ

CRANE & RIGGING

R. LITZ & SONS Co. Ltd. www.litzcranes.com

277 McPhillips St.
Winnipeg, Mb. R3E 2K7
Ph: (204) 783-7979
Fax: (204) 775-3250

Toll free: 1-888-CRANE03



info@litzcranes.com

'SERVING INDUSTRY SINCE 1903"

SWP – Lock Out / Tag Out Do's and Don'ts

Do's

- Follow the LOTO (lock out/tag out) established by our company
- Personally de-energize, lock out and tag out all power circuits and electrical equipment before any work is done on such circuits and equipment
- Personally de-energize, lock out and tag out all start-up switches on mechanical equipment before any work is done on such equipment
- Make sure that each person working on an electrical circuit or system applies his or her own personal lock and tag
- Make sure that all persons, including yourself are in a safe location before energizing any equipment
- Wear appropriate PPE, including but not limited to proper gloves, hard hat, and eye protection and safety boots
- Always ensure that all de-energizing, blanking, or other security devices are in place
- Always block machinery against motion even after it has been LOTO
- Always familiarize yourself with electrical circuits before you perform any electrical work. Ask for help or consult a wiring diagram/schematic
- Make sure that electrical work is performed only by a qualified electrician or persons trained to do electrical work under the direct supervision of a qualified electrician
- Make sure that all electrical circuits and circuit breakers are properly identified before trouble shooting or performing electrical work
- Check for proper grounding of power conductors where required
- Use properly rated non-contact voltage testers to ensure that circuits are de-energized
- Take battery cable off of battery post when working on vehicles
- Provide an audible or visible warning system to warn persons that a conveyor is starting
- Maintain electrical meters and testing instruments in good condition to verify that the circuit is de-energized before beginning work
- Communicate your intentions to work on an electrical circuit to ensure the circuit is, and remains, protected

- Provide safe access to all working areas
- Discharge all capacitors after the circuit has been locked out
- Relieve hydraulic and pneumatic pressure after equipment has been locked out and before performing maintenance
- Isolate all energy sources, including, electric, hydraulic, and mechanical and pneumatic before commencing work.

Don'ts

- Never defeat manual or automatic de-energizing devices
- Never remove guarding to perform maintenance or inspection until the machine has been properly de-energized and LOTO
- Never perform maintenance or work on moving machines
- Never rely on someone else to de-energize or disconnect a circuit for you
- Never remove someone else's lock or tag
- Never perform work on an electrical circuit before testing to make sure it has been de-energized
- Never remove or disturb an electrical lock or tag
- Never assume that a circuit breaker will not be reset by someone else. ALWAYS LOCK IT OUT
- Never loan or share your lock or key with someone else

LITZ
CRANE & RIGGING

R. LITZ & SONS Co. Ltd. www.litzcranes.com
277 McPhillips St.
Winnipeg, Mb. R3E 2K7
Ph: (204) 783-7979
Fax: (204) 775-3250
Toll free: 1-888-CRANE03

MEMBER
SC&RA
info@litzcranes.com

'SERVING INDUSTRY SINCE 1903'



SWP - Lock Out / Tag Out

Why there are standard practices for LOTO (lock out / tag out)?

To prevent injury, resulting from the unexpected movement of equipment, or the release of energy. There are many injuries each year in Canada which are the result of people being in contact with equipment which has not been properly isolated before working on or around it.

What are the four rules to LOTO?

- Isolate!
- Lock!
- Tag!
- Check!

The consequences of not following the rules to LOTO are injury or death, from the unexpected movement of equipment or the release of energy when you least expect it.

How to apply the rules?

Know the standard practices for LOTO. Look around for anything that could present a hazard to you before beginning work in your workplace. Identify all sources of energy for the specific hazards you have found. These are the items that you must isolate. You lock these items out of service to ensure you remain protected from the hazards. You place a tag at the lock to identify who has locked the equipment out. Then you check the equipment to ensure it has been isolated before beginning your work.

Definitions

Term	Definition
Authorized Switch Operator	A person who; <ul style="list-style-type: none">• Has been warned of the hazards involved with operating electrical switching devices and• Has been trained to operate a switch and• Has been trained to operate a switch and• Has been documented in the training records that the appropriate training has taken place and;• Has been authorized to operate switches by supervision
Prime Mover	A device, which uses energy to put equipment into motion, Such as an electric motor, internal combustion engine or air tugger.
Hand-off –Auto Selector	A device used to select whether equipment is to operate in a hand (manual) or automatic mode
Locking Device	A device which secures equipment in the isolated position when applied with a personal
Lock Extender	A device which secures equipment in the isolated position when applied with a personal lock e.g. valve lockouts, plug lockouts, and circuit breaker lockouts
Personal Lock	A uniquely keyed lock used to protect an individual while working on or near equipment
Restraint	A device used to prevent the energy stored in a mechanical system from releasing and causing equipment motion for the protection of personnel working on or near the equipment
Start/Stop Station	A device used for starting or stopping electrical equipment
Switch	A device for opening or closing an electrical circuit. For lock and tag purposes a breaker operating handle or lever may be considered a switch
Valve	A device for opening or closing a pneumatic, hydraulic, gas, process or service line
Tagger	The person who has tagged a piece of equipment
Working Ground	Wires or cables used to temporarily connect the electrical conductors of a circuit to ground, for the protection of personnel working on or near the conductors

General Instructions

1. Never operate equipment which is tagged out. The tag's purpose is to protect personnel or equipment. Operating tagged out equipment puts you and your workmates at risk or injury
2. Locking and tagging of equipment at a control mechanism is not acceptable because it puts personnel at risk of injury. Equipment must be isolated from its source of energy. For example, an electric motor cannot be electrically isolated at its start/stop station
3. To isolate high voltage equipment (greater than 750v AC or 300v DC) specific training and authorization is required and in some cases specific procedures must be followed. Only authorized switch operators with specific training and authorization may operate high voltage equipment.
4. An alternate means of ensuring equipment remains isolated must be used in cases where a personal lock cannot be applied. For example, if a locking device cannot be installed on a breaker in a lighting panel then an electrician can isolate the equipment by disconnecting the wire at the breaker.
5. Qualified personnel working on equipment for the purpose of supply verification equipment commissioning, operational testing or troubleshooting are not required to isolate, lock, tag and check equipment for that work. Personnel engaged in these activities must ensure they are protected from all hazards by following safe work practices and using appropriate personal protective equipment.

Types of Tags

There are three different types of tags

1. The **"Personal Protection"** tag

This is a red danger tag. The tag is for your protection while you are working on, or near, equipment which is a hazard. The tag identifies to others that you would be in danger if someone were to restore energy to the equipment

Every individual must ensure his or her own safety by applying their own personal lock and tag.

This lock and tag must be removed by you the tigger, when you've finished working on the equipment for the day. This is necessary because you no longer require protection and failure to remove your lock and tag will be an inconvenience to others.

If you've left work without removing your lock and tag then someone will attempt to contact you to have them removed before the equipment can be operated. A supervisor will have to be contacted if you cannot be reached. The supervisor will then have to determine if your lock and tag can be removed by physically checking that you are not in the area of the equipment.

Never remove someone else's personal lock and personal protection tag unless you have the authority to do so. By removing someone else's lock and tag you could be putting them in danger.

2. The **"Equipment Status"** Tag

This is a white caution tag. It is used to indicate equipment that is not suitable for operation and may create a hazard if operated. Examples are equipment which is broken down or equipment which is not fully installed. Equipment status tags are not used for personal protection. Personal locks are not used with these tags.

Checking equipment after isolation to ensure it won't start or move isn't required. If the equipment is not suitable for operation then trying to start it may cause a hazard or equipment damage.

Equipment status tags can be removed by anyone who is knowledgeable of the status of the equipment and knowledgeable of how operating the will affect the plant. Examples of personnel who may remove "Equipment Status" tags are the person who attached the tag or that persons supervisor or the operational supervisor for the area.

3. The **"Superintendent's Hold"** Tag

This is a red and white striped danger tag. The tag serves the same purpose as the equipment status tag – to indicate equipment is not suitable for operation and may create a hazard if operated. The tag is not used for personal protection.

The tag is intended to be used when specific personal knowledge of equipment or work status is required before the tag is removed. An example might be a maintenance supervisor coordinating a long-term multi-trade rebuild of machinery. The tag may be applied by anyone in such a position.

The difference from an Equipment Status tag is:

- The tag requires the written approval of the plant superintendent or a designate, and
- The tagger applies a personal lock with the tag, and
- The tag can only be removed by the tagger or the superintendent (or designate) in the taggers absence.

Details of Locks, Lock Extenders, and Tags

1. Personal locks do not have a master key. Your key must be the only one in existence.
2. When your personal lock is used keep the key in your possession
3. Lock boxes may be used when more than one person is locking equipment out for personal protection. Each person requiring protection must apply their own lock and tag to the box.
4. Use a lock extender when there is only one position remaining on the equipments locking mechanism for the attachment of a personal lock, and an additional personal lock is to be attached. The lock extender will allow additional workers to attach their personal locks.

5. Lock extenders must be attached directly to the equipments locking mechanism or another lock extender in such a way that the equipment cannot be operated without first removing all personal locks and lock extenders
6. All tags must be securely attached so they will not fall or be blown off
7. All information written on tags must be clear and legible

Electrical Equipment

Purpose

This part defines the requirements to ensure electrically powered equipment will not be able to start or release electrical energy. These standard practice instructions apply to all electrically powered equipment, regardless of operating voltage.

General

Only authorized switch operators may operate switches, with exception to lighting panel load breakers at 240v or less. Lighting panel load breaker at 240v or less may be operated by anyone working under the authority of Inco.

Request the assistance of an authorized switch operator if you are not authorized to operate a switch

Standard Practice for Isolating Equipment

1. Identify the name and number of the equipment to be isolated. Equipment identification will be posted at the prime mover. The information is required to ensure the correct switch is used to isolate the equipment. Workers will be at risk if the wrong equipment is isolated
2. Ensure the equipment is not operating. If the equipment is operating then it must be stopped. Notify operating personnel that the equipment will be taken out of service, and request their approval if it will affect operations.
Opening switches while equipment is running, and especially when equipment is starting will cause unnecessary wear to the switch. Given unusual circumstances the switch may even fail catastrophically, creating the potential for injury to anyone near the switch.
3. Put the hand-off auto selector (if there is one) in the off position. Or defeat automatic starting by other means, to prevent the equipment from starting while it's being isolated. Tag the selector to ensure the automatic controls remain disabled.
4. Tag any and all field start/stop situations. This will prevent other people from starting the equipment while it's being isolated.
5. Go to the switch which will be used to isolate thee equipment. Confirm the equipment blame and number on the switch matches the identification found at the prime mover.

Standard Practice for Isolating Equipment

1. Identify the name and number of the equipment to be isolated. Equipment identification will be posted at the prime mover. The information is required to ensure the correct switch is used to isolate the equipment. Worker will be at risk if the wrong equipment is isolated.
2. Ensure the equipment is not operating. If the equipment is operating then it must be stopped. Notify operating personnel that the equipment will be taken out of service and request their approval if it will affect operations.
3. Put the Hand-off auto selector (if there is one) in the off position, or defeat automatic starting by other means, to prevent the equipment from starting while it's being isolated. Tag the selector to ensure the automatic controls remain disabled.
4. Tag any and all field start/stop situations. This will prevent other people from starting the equipment while its being isolated
5. Go to the switch which will be used to isolate the equipment. Confirm the equipment name and number on the switch matches the identification found at the prime mover.
6. If the identification matches then proceed to open the switch. The approved manner to open a switch is:
 - Turn the hand-off auto selector to the off position and pres the stop push button, if they exist at the switch. This is a final check to make sure the equipment isn't running.
 - Stand to one side of the switch in a position which doesn't require you to reach across the door of the switch to operate the handle. Turn your face and body away from the switch. This position will minimize injuries should there be a catastrophic failure of the switch operating handle to its off position.
7. Apply a lock if the equipment has been isolated for protection of personnel. Try to close the switch. This will ensure the lock has been applied correctly and is holding the switch open
8. Tag the switch with the type of tag required for your particular situation
9. If equipment has been isolated for personal protection return to the hand-off-auto or start/stop station. With the hand-off auto selector in the hand (manual) positions, try to start the equipment. If the equipment doesn't start then you can proceed with your work, if the equipment starts do not work on the equipment. Immediately remove your personal protection tag and place a Status Tag on the switch indicating it has failed. Immediately notify supervision of the incident.

Returning Equipment to Service

1. Inform operational personnel that the equipment is being returned to service

2. Check that all work mates are clear and equipment is ready for service
3. Confirm the equipment name and number at the prime mover is the same as the equipment name and number at the switch.
4. Remove you lock and tag at the switch. If there are locks and tags on the equipment which you are not authorized to remove then the equipment cannot be returned to service until these locks and tags are removed by authorized personnel.
5. The switch may now be closed. The approved manner to close a switch is:
 - Ensure the hand-off auto selector is in the off position and press the stop pushbutton, if they exist at the switch. This is a final check to ensure the equipment will not start as the switch closes
 - Stand to one side of the switch in a position which does not require you to reach across the door to the switch to operate the handle. Turn your face and body away from the switch. This position will minimize injuries should there be a catastrophic failure of the switch as it is closed. Move the switch operating handle to its "on" or "closed" position.
6. Remove all tags which had been placed at hand-off auto selectors and start/stop stations. If equipment is being returned to service then selectors must be returned to their normal operating position.

Special Requirements for Electrical Work

1. Personnel performing electrical work must visually confirm (where possible) that each switch blade or breaker contact is open and use voltage testers to test for energized conductors, to ensure power has been removed from all conductors before anyone works on or near the electrical conductors.
2. Working grounds must be installed on the conductors of all circuits which are a potential source of energy if electrical work is to be done on or near, electrical conductors operating above 750v. The grounds must be installed before work on conductors begins.
3. A tag must be placed at the switch indicating working grounds are in use and identifying the location of the working grounds. Also tag the working grounds
If working grounds are to remain installed for more than one shift then the grounds must be checked each shift before work starts.
It is also good practice to place working grounds on low voltage conductors before working with them

Mechanical Equipment and Systems

Purpose

This part defines standard practices which ensure mechanical equipment and systems will not be able to move or release energy. These standard practices are applicable to all pneumatic and hydraulic powered equipment, regardless of the operating pressure.

Mechanical equipment means any equipment, machinery or apparatus where the energy to operate the equipment is derived from non-electrical sources. Mechanical equipment includes equipment used for the transmission of non-electrical services or the transport of materials.

Standard Practices

1. All equipment which could cause a hazard to personnel, or damage if operate, shall be closed or placed into a safe position, locked tagged and checked. This includes valves service lines, gates, doors, chutes, etc.
2. Restraints, valve lockout covers, or similar locking devices shall be installed to secure equipment in a safe position
3. Particular care is required when isolating pressurized systems or equipment which incorporates stored energy devices. Some examples are pressurized service lines, system header, air receivers, accumulators, tanks and charged springs
Ensure the pressure or stored energy is released, or isolated, prior to working on the equipment. Pressurized systems shall have the pressure bled off between the isolation device and the work area prior to starting work on all system
The preferred method of isolation in order of preference is:
 - “double block and bleed”
 - “block, bleed and blank”
 - “block, bleed and physical disconnect”

“Double block and bleed” shall be used whenever possible. Where none of the above is possible, special procedures authorized by supervision must be in place to ensure worker safety.

4. All new equipment and systems shall be designed and installed with “double block and bleed” isolation capability, including additions to existing equipment and systems
5. When working with highly corrosive liquids, lethal gasses, high temperatures, very high pressures, etc. refer to specific work procedures for special precautions and procedures
6. Where equipment has both electrical and mechanical energy sources standard lock and tag practices for all of these hazards must be followed to ensure you and your workmates are safe. For example, to remove a steam unit heater with an electrical fan and the steam supply to the heater.
Personnel must be aware of any other potential hazards involved in working on mechanical equipment (i.e. pinch points, hot components, possibility of equipment rolling or moving, etc.) before commencing work on the equipment.

Mobile Equipment

Purpose

This part defines standard practices which ensure mobile equipment will not be able to move or release energy. These standard practices are applicable to all mobile equipment, regardless of purpose, size, power source, or type of drive system.

Mobile equipment means any fuel, air or electrically powered vehicle which is capable of moving from place to place under its own power. Mobile equipment includes scoop trams (LHD's), drills, jumbos, service trucks, utility vehicles etc.

Standard Practices

1. Mobile equipment which is not to be started or moved because of mechanical breakdown or some other dangerous condition shall be isolated, locked if possible, and tagged with an equipment status tag. Reasons or conditions shall be identified on the tags
2. Mobile equipment which is under repair shall have all hazards isolated, locked if possible tagged and checked. Personal protection tags shall be used while working on the equipment.
3. Locks and tags shall be placed at the main disconnect switch of electrically powered equipment. Equipment without a main disconnect switch shall have a tag placed on the ignition switch.
4. Refer to equipment specific procedures and manufacturer's recommendations prior to working on mobile equipment. All maintenance and other work on mobile equipment shall be done in accordance with the equipment manufacturers maintenance manuals and procedures
5. Personnel must be aware of all potential hazards involved in working on mobile equipment (i.e. pinch points, hot components, hot exhaust systems, possible electrical shock, possibility of equipment rolling or moving, etc.)

CAUTION: Particular care is required when working on mobile equipment which incorporates stored energy devices (air receivers, hydraulic accumulators, pressurized system headers, charged springs, etc.) To ensure that the stored mechanical energy is safely released or isolated prior to working on the equipment.

LITZ

CRANE & RIGGING

R. LITZ & SONS Co. Ltd. www.litzcranes.com

277 McPhillips St.
Winnipeg, Mb. R3E 2K7
Ph: (204) 783-7979
Fax: (204) 775-3250

Toll free: 1-888-CRANE03



info@litzcranes.com

'SERVING INDUSTRY SINCE 1903'

SWP – Mobile Equipment

Do's

- Be a Litz Cranes employee and maintain a valid driver's license
- Whenever complete focus on the safe operation of the vehicle cannot be maintained (i.e. adjusting controls, filling out logbooks, lack of vision due to sunlight etc.) the operation of the vehicle must come to a full arrest prior to commencing/completing any additional task.
- Operate equipment in a safe and professional manner
- Inspect all equipment prior to operating, report and correct all defects prior to using equipment
- Wear seatbelts at all times
- A walk around inspection must take place prior to moving a vehicle or any mobile equipment to ensure people, equipment and materials are clear from the intended path of travel.
- Properly use all steps, handrails, and grab irons. Properly face the equipment when mounting or dismounting, always use 3 point contact.
- The driver or operator of the vehicle or equipment is responsible for the safety of all passengers. Passengers must be safely and securely seated in the cab of the vehicle when it is in motion
- Ensure vehicle is in park or its equivalent and that parking brake is set prior to exiting the vehicle or leaving vehicle unattended
- Do get driver or operator of vehicles permission prior to getting on or off the vehicle or equipment
- Keep vehicles and equipment in appropriate gear/drive range at all times when moving, select the proper gear/drive range prior to starting downgrade or hill. Freewheeling or coasting downgrade is neutral is prohibited
- Lights, flares, or other warning devices shall be posted when parked or disabled vehicles, or equipment or road conditions create a hazard to vehicle, equipment or traffic
- Be certain that all persons are clear before starting or moving vehicle or equipment
- Bring vehicles and equipment to full stop and sound horn, prior to entering a building entrance

- Keep the cab of the vehicle or equipment neat and in tidy condition. The possession of reading material other than the Litz Cranes Safety, Loss Prevention Book, or training manual in the cab of vehicles or mobile equipment is prohibited
- In the event that a vehicle or mobile equipment catches fire, the driver or operator shall stop the vehicle, turn off the engine, set the parking brake, and if possible, block the vehicle or equipment wheels on the downgrade side, to protect other workers and equipment. Use portable extinguisher and call for help as soon as possible
- Do have lights on both ends as required for safe operation, for all trucks, front end loaders, graders and dozers, that are operated at night
- Inspect all units for damage, fluid leaks and for low tires and ensure all lights are functional
- Start vehicle so as to give it proper time to warm up prior to use, give more time as temperatures get colder
- Do check brakes, air pressure, and test brake operation prior to use.
- When pulling a trailer ensure to check the air line connection, electrical connection, lights, and brake operation before leaving the yard or job site.
- Ensure that when you return to the yard, you fuel your truck, check oil, and enter any mechanical work required on the unit log book. Advise the dispatcher of any repair work needed
- If you are arriving at a site with a tractor unit: to move pin load, be sure that the unit being moved, is equipped with proper brakes, lights, and that tires are properly inflated and in good condition
- Do flag any loads extending beyond the rear of the trailer properly
- When hauling a load on a highboy or lowboy, ensure that the load is free of any rocks, dirt, and loose pieces of debris/material. Always ensure that the load is properly secured

Do Not's

- Drive vehicles, hauling equipment, or mobile equipment unless you are authorized to do so and have all training and licensing required
- Operate a vehicle while performing any additional task other than the safe operation of that vehicle. If adjustments to non critical controls must be made the operation must be ceased prior to the adjustment.
- Do Not use cell phones at any time while vehicle is in use.
- Allow any unauthorized persons to drive, operate or ride on any vehicles or equipment
- Do not operate at a speed which will endanger any person or property. The driver or operator must keep his/her equipment under control at all times and always drive according to conditions, slowing down ahead of curves, on wet roads, steep ramps, for heavy traffic, or poor visibility
- Do not get on or off moving vehicles or equipment
- Do not use portable music-radios, such as Mp3 players are not allowed in Litz Cranes vehicles or Equipment

- Do not follow too close to other vehicles a 3 second gap between you and the vehicle in front of you , increasing the gap as road conditions worsen
- Do not pass on a downgrade is prohibited except where a vehicle is slow moving or working equipment, they may be passed in areas of adequate clearance and visibility.
- Do not transport supplies, materials and tools, other than small hand tools, with employees in personnel trip vehicles unless such personnel trip vehicles are specifically designed to make such transportation safe. Aerosol cans shall not be transported in cabs

*****Warning: failure to follow any of the above safety instructions could result in serious injury or death. Always use equipment for the purpose for which it was designed as explained in the operators manual*****



CRANE & RIGGING

R. LITZ & SONS Co. Ltd. www.litzcranes.com

277 McPhillips St.
Winnipeg, Mb. R3E 2K7
Ph: (204) 783-7979
Fax: (204) 775-3250

Toll free: 1-888-CRANE03



info@litzcranes.com

'SERVING INDUSTRY SINCE 1903'

SWP – Particulate Matter

What are Particulates?

Particulate matter is the name given to solids or liquids that are distributed in a gas. In the workplace, most often the term particulates refers to particles, dust, mist or fume that has become suspended in the surrounding air. Persons breathing in particulate matter may not be aware of what they are inhaling as well as to whether or not it has any acute or chronic affects.

What parts of the respiratory system can be affected?

The diagram below shows the parts of the respiratory system. It can be divided in to 2 systems – the upper airway passages and the lower airway passages. The upper airway passages, includes the nose, nasal passages, mouth and the pharynx down to the vocal cords in the larynx(voice box or Adams apple). The lower airway passages start at the vocal cords, and extend down the trachea (wind pipe) and continue all the way down to the small air sacs (alveoli) at the end of every branch of the bronchial tree. The bronchial tree includes the trachea, the bronchus (branches of the trachea going to each lobe of the lung), and bronchioles (branches of the bronchi).

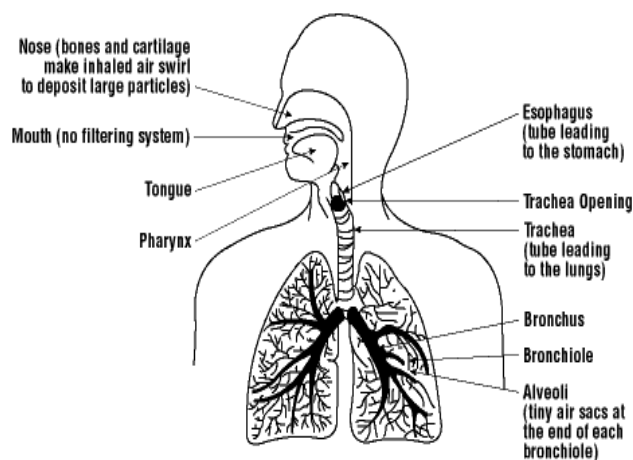

Particulate Deposition in the Lungs

Inhalation is the most important route of exposure in the workplace. How far a particle gets into the respiratory system and what it does when it is deposited, depends on the size shape and density of the particulate material. What happens when the particle has entered the respiratory system on the chemical and toxic properties of the material.

Particles are deposited in the lungs by one of four different ways: Interception, Impaction, Sedimentation, and diffusion

LITZ

CRANE & RIGGING

R. LITZ & SONS Co. Ltd. www.litzcranes.com

277 McPhillips St.
Winnipeg, Mb. R3E 2K7
Ph: (204) 783-7979
Fax: (204) 775-3250

Toll free: 1-888-CRANE03



info@litzcranes.com

'SERVING INDUSTRY SINCE 1903'

SWP – Pipe Bending

A bending machine is used to shape the pipe to conform to the contours of the terrain or to change the direction of the line route.

Do's

- Regularly inspect equipment
- Remain within the operators line of vision
- Wear appropriate clothing and personal protective equipment
- Keep proper distance when tagging pipe
- Keep pipe from swinging
- Know the proper hand signals
- Check pipe slings for wear and defects
- Make sure the pipe is properly chalked

Don'ts

- Engage in horseplay
- Ride on equipment unless appropriate seating is available
- Enter equipment hazard zones
- Stand between pipe and equipment
- Stand pipe and ditch
- Wear jewellery or loose clothing
- Walk under suspended loads
- Jump off equipment
- Use drugs or alcohol
- Take unnecessary chances
- Get hands between the pipe and the bending machine
- Commence the bending process until all workers are clear

LITZ

CRANE & RIGGING

R. LITZ & SONS Co. Ltd. www.litzcranes.com

277 McPhillips St.
Winnipeg, Mb. R3E 2K7
Ph: (204) 783-7979
Fax: (204) 775-3250

Toll free: 1-888-CRANE03



info@litzcranes.com

'SERVING INDUSTRY SINCE 1903"

SWP – Propane Heaters

Do's

- All flammable materials
- Place the heater on a level, hard, non-flammable surface, such as a ceramic tile floor.
- Turn heater off when you leave the area or it is no longer required
- Coil extra hose
- Protect hosing from punctures and snags
- Store propane cylinders outside or in a well ventilated area
- Use caution when igniting heater
- Be mindful of carbon monoxide

Don'ts

- Leave flammable materials near including the propane cylinder near the heater
- Have a heater hose longer than 50 feet
- Leave heater running when it is no longer required
- Leave heater running without it being ignited



CRANE & RIGGING

R. LITZ & SONS Co. Ltd. www.litzcranes.com

277 McPhillips St.
Winnipeg, Mb. R3E 2K7
Ph: (204) 783-7979
Fax: (204) 775-3250

Toll free: 1-888-CRANE03



info@litzcranes.com

'SERVING INDUSTRY SINCE 1903"

SWP – Small Tool Procedure

Do's

- Always keep small tools in a safe working condition by regular inspections and maintenance
- Always wear personal protective equipment, including shielded safety glasses or goggles.
- All small tools should be used only for the purpose for which they were designed (ex. A wrench is not a hammer)
- Turn off and disconnect the power source when power tools are left unattended
- Properly maintain portable electric tools that require a ground wire ensuring that the ground wire is in good shape and that the plug ground prong has not been removed
- Be sure your work area is clean. Oily rags, sawdust, papers and other clutter can easily be ignited by sparks or heat.
- Make sure the tool is turned off and unplugged from the power supply before you inspect it or install bits or blades
- Keep guards and other safety devices in place.
- Immediately turn off and unplug any tool that sparks, overheats or causes an electrical shock.
- Keep power tools clean, sharp and in good operating condition.

Don'ts

- Use defective tools like those with cracked belts, defective handles or mushroomed heads
- Carry sharp edged or pointed tools in pockets
- Use power tools and cords in wet areas
- Overreach or use a power tool while standing on a ladder. Plant your feet firmly on the floor.
- Try to fix a defective power tool yourself.
- Don't use the tool if it needs repair. Report any problems to your supervisor.

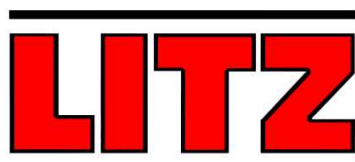

CRANE & RIGGING

R. LITZ & SONS Co. Ltd. www.litzcranes.com

277 McPhillips St.
Winnipeg, Mb. R3E 2K7
Ph: (204) 783-7979
Fax: (204) 775-3250

Toll free: 1-888-CRANE03



info@litzcranes.com

'SERVING INDUSTRY SINCE 1903'

SWP – Welding

General

- Welders shall check their equipment at frequent and regular intervals for defects, particularly for defective cables in wet areas
- Ensure buffing and grinding operators wear face shields, safety glasses, and hearing protection and all other related PPE
- Ensure full and empty cylinders be kept separate and identified
- Ensure cylinders are secured and in upright position
- Ensure flammable materials are kept out of weld areas
- Avoid watching arc without proper eye protection
- Ensure grinders and buffers have proper guards installed as per manufacturers specifications
- When welding or grinding use portable grinding/welding shields around the area where work is being done
- Have welding cables off the ground and up in walk areas
- No contact lenses when welding. Use glasses and CSA approved eye wear
- Never use bare conductors damaged regulators, torches or electrode holders
- Don't weld on wet surfaces

Gas Welding

- Cylinders have different thread patterns but valve connections do not and are therefore interchangeable and every effort should be made not to mess them up
- Oxygen has no smell and is not itself flammable. However, too much oxygen in the atmosphere can be extremely dangerous. If the gas impregnates materials which normally don't burn they are liable to burst into flame
- Acetylene is highly flammable and with oxygen may form an explosive mixture
- LPG is heavier than air so it will pool in low-lying areas

- Note all deficiencies and report to appropriate personnel
- Make sure all cables are wound securely when transporting.
- Do a “walk around” to check for damage and obvious leaks.
- Note all deficiencies and report to appropriate personnel.
- Any repairs should be done by qualified mechanics or technicians.

Gas Cylinder Storage

- Oxygen and acetylene cylinders should be stored at least 3 meters away from one another
- Cylinders shall always be stored and transported upright, out of the way of contact, and secured from tipping or falling over
- When cylinders are not in use protective caps must be on at all times!!
- Do not keep oxygen and acetylene in the same area group cylinders by type of gas
- Store cylinders so that the oldest cylinders will be used first
- Keep full cylinders separate from empty cylinders
- Mark all empty cylinders “MT”
- Do not store cylinders in direct sunlight or near sources of heat,
- Do not allow cylinder to be exposed to any violent contact take extra precaution to protect cylinders from falls by ensuring that cylinders are always secured

Regulators

- Cylinders must be fitted with regulators when in use, the regulators used must be designed for the gas it is being used with
- Periodic inspections of regulators is a must

Hoses

- Hoses should be colour coded for ease of identification
- Ensure that hoses are inspected daily to check for cuts, cracks, and burnt or worn patches

Non Return Valves and Flashback Arrestors

- Oxygen and fuel gas that become mixed in the hose, create a possibility of a mixed gas explosion or “Flashback” may occur.
- Flash arrestors should be in place at all times when equipment is in use

Electric Arc Welding

- Always inspect machine, cables, and equipment for damage and wear
- Use voltage as low as is consistent with efficient welding
- The welder return should be of a section not less than that of the welding lead
- Always ensure the welder return is firmly connected to the metal where welding is taking place
- Ensure that the electrode holder on the welding lead is fully insulated and that there are no bare portions where a person can come in contact with it accidentally
- Where all appropriate PPE

LITZ

CRANE & RIGGING

R. LITZ & SONS Co. Ltd. www.litzcranes.com

277 McPhillips St.
Winnipeg, Mb. R3E 2K7
Ph: (204) 783-7979
Fax: (204) 775-3250

Toll free: 1-888-CRANE03



info@litzcranes.com

SWP – Winter Driving Tips

Do's

- Keep your vehicle in good repair
- Anticipate crises and avoid them
- Reduce speed when road conditions/weather deem it necessary
- Keep tires inflated to appropriate levels
- Plan ahead with a winter safety kit for cases for emergency
- Use fluids designed for winter conditions i.e. coolant and windshield washer fluid
- Ensure that wipers function properly and effectively
- Be aware of changing road conditions/black ice
- Lengthen your following distance behind the vehicle in front of you

Don'ts

- Drive too fast for road/weather conditions
- Use tires that have worn tread or improper tread for winter conditions
- Mix radial tires with other types
- Drive on unbalanced and un aligned tires
- Drive on a cold engine
- Warm up your vehicle in an enclosed garage
- Drive too close to vehicles

A Winter Safety Kit Should Include:

- Sand or Kitty litter
- Snow shovel
- Snow Brush
- Ice Scraper
- Booster Cables
- Flares or emergency lights
- Fuel de-icer
- Extra Washer Fluid
- Flashlight
- Blanket
- Extra clothing
- Emergency food and water
- Safety matches and emergency candles

What to do if you become stranded:

- Don't Panic
- Avoid over-exertion and over-exposure to the cold. Cold weather can put extra stress on the heart and contribute to the hazards of over-exertion. Sweaty clothes next to the skin are not good insulators against the cold
- Stay in the car if you cannot shovel your car out of the snow
- Stay in the car in blizzard conditions – Do not leave the car for assistance unless help is visible within about 90 meters or 100 yards
- Turn on hazard lights and set up flares or emergency lights
- Run the car engine occasionally (about 10 minutes every hour) to provide heat (and to conserve fuel). Ensure that the tail exhaust pipe is free of snow and keep the window opened slightly (on the side shielded slightly from the wind) to prevent the build up of carbon monoxide when the engine is running
- Bundle up in a blanket. If there is more than one person in the car, share – two people sharing blankets will be warmer than either person alone in a blanket
- Wear a hat and scarf – the head and neck are major sources of heat loss from the body
- Monitor for any signs of frostbite and hypothermia
- Do not fall asleep. If there is more than one person in the car take turns sleeping
- Do not stay in one position too long. Do some exercises to help the circulation – move arms and legs, clap hand etc.
- Watch for traffic rescuers

Employee Safe Work Practice Sign-Off

Employee Name (print full name): _____

Date: _____

#	Practice	Initial to Sign-Off
	F Point Harness Inspection	
	G Aerial Buckets	
	H Aerial Devices	
	I Asbestos	
	I Cable Clips and Clamping Wire Rope	
	I Chain Saw – Basic Operation	
	I Chain Saw – General Safety	
	I Chain Saw – PPE	
	J Chain Saw – Safe Use Of	
	F Chemical Hazard Recognition	
	F Chop Saw	
	F Clothing in the Electrical Industry	
	F Compressed Air – Use	
	F Compressed Gas – Cylinder Storage	
	F Compressed Gas – Regulator Use	
	F Confined Space	
	F Construction Labourers	
	F Directional Drilling	
	F Electrical – Live Apparatus	
	G Electrical Safety	
	G Electrical Shock Protection	
	G Explosive Actuated Fastening Tool	
	G Extension Cords	
	G Extension Ladder	
	G Extreme Temperature Work	
	G Fire Precautions	
	G First Aid for Chemical Exposure	
	28. First Aid	
	29. Flammable Liquids	
	30. Grinders – Portable	

31. Grinding	
32. Guardrails	
33. Hack Saw	
34. Hand Saw Safety	
35. Hazardous Material Precautions	
36. High Voltage Lines	
37. Hoisting Personnel	
38. Hot Work	
39. Hypothermia	
40. Illumination & Fixed Temporary Lighting	
41. Labelling Containers	
42. Ladders – Extension Safety	
43. Ladders – Extension Set Up	
44. Ladders – Portable Safety	
45. Lock Out – Tag Out – Do's and Don'ts	
46. Lock Out – Tag Out	
47. Mobile Equipment	
48. Particulates and the Respiratory System	
49. Pipe Bending	
50. Propane Heaters	
51. Small Tools	
52. Welding	
53. Winter Driving	